

The Wheatstone Bridge

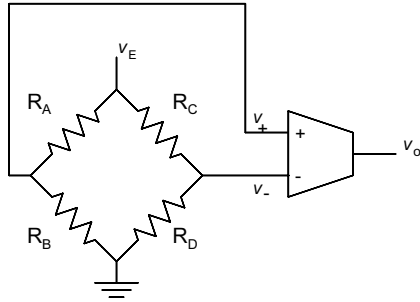

Raison d'être: convert tiny changes in resistance to voltage.

Shown with an *instrumentation amplifier*.

Like an ideal op-amp but with finite gain.

Gain of instrumentation amplifier denoted by A .

$$v_o = A(v_+ - v_-).$$

The Wheatstone bridge consists of four *arms*.

$$v_o = A \left(\frac{R_B}{R_A + R_B} - \frac{R_D}{R_C + R_D} \right) v_E.$$

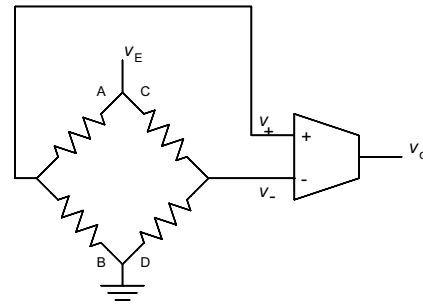

Transducer can be placed in one, two, or four arms.

Typical function: $H_t(x) = R(1 + xk)$, $xk \ll 1$

where R is the nominal resistance of the transducer and k is a constant.

For simplicity write function as: $H_t(x) = R + R_s$,

where R is independent of the process-variable value and R_s is dependent on the process-variable value.

Typically, $R \gg R_s$.

Usually, need to convert R_s to a voltage.

Complementary Pairs

Frequently, transducer pairs can have *complementary responses*.

If so, there are two (usually identical) transducers...

...positioned so they react *oppositely* to the process variable...

...so that when their responses are *subtracted*...

...their response to the process variable *add*...

...and unwanted quantities *cancel out*.

For example, consider:

$$H_{t1}(x) = R(1 + xk) \text{ and } H_{t2}(x) = R(1 - xk).$$

Sum: $H_{t1}(x) + H_{t2}(x) = R$. (Not helpful.)

Difference: $H_{t1}(x) - H_{t2}(x) = 2xk$. (Much better.)

One-Transducer Configuration

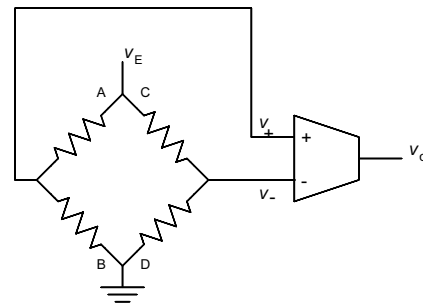

Arm B: $H_t(x) = R + R_s = R(1 + xk)$.

Other Arms: Resistor of value R .

$$v_o = A \left(\frac{R_s}{2(2R + R_s)} \right) v_E \approx A \frac{R_s}{4R} v_E = A \frac{xk}{4} v_E.$$

Two-Transducer Configuration

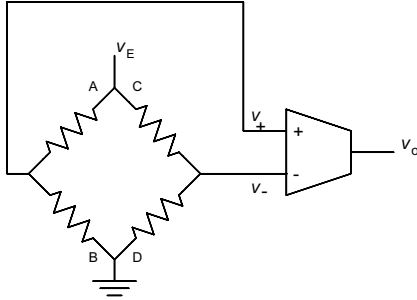

$$\text{Arm A: } H_{t2}(x) = R - R_s = R(1 - xk).$$

$$\text{Arm B: } H_{t1}(x) = R + R_s = R(1 + xk).$$

Other Arms: Resistor of value R .

$$v_o = A \frac{R_s}{2R} v_E = A \frac{xk}{2} v_E.$$

As one might expect, twice as sensitive.

Four-Transducer Configuration

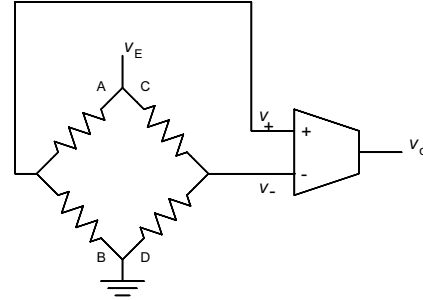

$$\text{Arms A and D: } H_{t2}(x) = R - R_s = R(1 - xk).$$

$$\text{Arms B and C: } H_{t1}(x) = R + R_s = R(1 + xk).$$

$$v_o = A \frac{R_s}{R} v_E = A xk v_E.$$

Wheatstone Bridge Transfer Functions

Goal

Let $R_t = R \pm R_s = R(1 \pm xk)$ be the transducer response(s).

Assume bridge designed properly.

Need to find two functions:

$$H_c(R_t) = \dots \quad \text{and} \quad H_c(R_s) = \dots$$

Both functions are equivalent.

Choose whichever is more convenient.

Four-Transducer Configuration

$$H_c(R_s) = v_o = A \frac{R_s}{R} v_E.$$

Let $R_t = R + R_s$. Then $R_s = R_t - R$.

$$H_c(R_t) = A \frac{R_t - R}{R} v_E = A \left(\frac{R_t}{R} - 1 \right) v_E.$$

Two-Transducer Configuration

$$H_c(R_s) = v_o = \frac{A}{2} \frac{R_s}{R} v_E.$$

$$H_c(R_t) = \frac{A}{2} \frac{R_t - R}{R} v_E = \frac{A}{2} \left(\frac{R_t}{R} - 1 \right) v_E.$$

One-Transducer Configuration

$$H_c(R_s) = v_o = \frac{A}{4} \frac{R_s}{R} v_E.$$

$$H_c(R_t) = \frac{A}{4} \frac{R_t - R}{R} v_E = \frac{A}{4} \left(\frac{R_t}{R} - 1 \right) v_E.$$

Wheatstone Bridge Sample Problem

Design a system with output $v_o = H(x)$, where process variable x is strain and, $x \in [0, 10^{-5}]$, and $H(x) = 10^6 x \text{ V}$.

Strain will be covered in more detail later.

For now, all we need to know is that strain is dimensionless.

Strain is measured by a *strain gauge*.

Strain gauges frequently used in complementary pairs.

Use strain gauges with response:

$$H_t(\epsilon) = R(1 + \epsilon G_f),$$

where ϵ denotes strain and

constant $G_f = 2$.

(G_f called *gauge factor*, a dimensionless quantity.)

Position the two strain gauges to obtain response:

$$H_t(x) = R(1 + xG_f) \quad \text{and} \quad H_t(x) = R(1 - xG_f).$$

Derivation of Conditioning Circuit Needed

A Wheatstone bridge is the obvious choice because transducer response is in form $R \pm R_s$.

Nevertheless, conditioning-circuit derivation will be presented.

$$H(x) = H_c(H_t(x))$$

(Analysis performed as though there were one transducer.)

$$y = H_t(x) = R_t = R(1 + xG_f). \text{ Then } x = \frac{\frac{y}{R} - 1}{G_f}.$$

$$\text{Then } H_c(y) = H\left(\frac{\frac{y}{R} - 1}{G_f}\right) = 10^6 \frac{\frac{y}{R} - 1}{G_f} \text{ V.}$$

$$\text{Response for two-transducer configuration: } H_c(R_t) = \frac{A}{2} \left(\frac{R_t}{R} - 1 \right) v_E.$$

Choose A and v_E so that $\frac{A}{2} v_E = \frac{10^6}{G_f} \text{ V}$ is satisfied.

For example, $v_E = 10 \text{ V}$ and $A = 10^5$.