

Displacement and Proximity

Displacement transducers measure the location of an object.

Proximity transducers determine when an object is near.

Criteria Used in Selection of Transducer

- How much force can transducer exert on object?
Requirement can be as low as zero when the object is small or cannot be touched.
- What is the range of positions to be measured?
- How fast will the object be moving?
- What accuracy is required?

Types of Displacement Transducers

Potentiometer.

Object moves tap on a variable resistor.

Linear Variable Differential Transformer (LVDT).

Object moves core of three-winding inductor.

Capacitive Transducers.

Object is either one plate of a capacitor, or moves the capacitor's dielectric.

Coded.

Object moves surface covered with code marks. A transducer reads the code marks.

There are many other ways to measure position . . .

. . . these will not be covered individually . . .

. . . but may be explained as part of problems.

Potentiometers

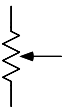

Symbol:

Construction and Operation:

Resistive material formed into either a strip or coil.

An external object, through a mechanical linkage, moves the tap.

Tap slides along resistive material.

Tap and both ends of resistive material connected to leads.

Miscellaneous Facts:

These are built for instrumentation purposes.

(Unlike the volume control on a radio.)

Multiple-turn potentiometers can be made precise.

(Percent calibration error less than 1%.)

Desirable Characteristics

- Easy to read output.
- Linear response. Other responses also possible.
- Inexpensive.

Undesirable Characteristics

- Adds friction to motion of object.
- Can wear out.
- Limited precision.
- Can only measure relatively large displacements.

Capacitive Displacement Transducers

Symbol: no special symbol used.

Two types discussed: *moving plate* and *moving dielectric*.

Construction and Principle of Moving Plate Type:

One plate of capacitor mounted to a fixed surface.

The other plate mounted to the object.

Capacitance changes with position of object.

Possible ways of mounting and moving plates:

- Plates move normal to plane of plates.
- Plates move parallel to plane of plates.
- Plates, shaped like pie slices, rotate.

Construction and Principle of Moving Dielectric Type:

Both plates of capacitor mounted to a fixed surface.

The dielectric mounted to an object.

Capacitance changes with position of object.

Possible ways of moving dielectric:

- Dielectric slides.
- Dielectric is a fluid that flows in and out of the capacitor.

Model Function

This varies for each type.

Moving-Plate Type

If the area of the plates is large compared to the distance between them

and one plate moves normal to its plane:

$$H_{11}(x) = C \frac{m}{x}, \quad x > 0 \text{ m.}$$

Moving-Dielectric Type

$$H_{11}(x) = C_0(1 + Kx),$$

where K is a constant determined by the transducer construction.

There are many variations on capacitive sensors, so there are many model functions.

Derivation and use of model functions for capacitive sensors is beyond the scope of the course.

Typical Conditioning Circuits

Oscillator

Capacitive transducer may be part of an LC pair in an oscillator.

Capacitance measured by counting frequency.

Bridge

Capacitive transducers can be placed in a bridge. (In the same way as resistive transducers.)

AC voltage placed across bridge . . .
 . . . instead of DC, as with resistive transducers.

Bridge voltage is amplified, rectified, then measured.

Analysis of these circuits is beyond the scope of this course.

Desirable Characteristics

- No physical contact with object. (Moving dielectric type.)
- No wear with motion.
- Can measure small displacements. (Including the position of a diaphragm in some microphones.)

Undesirable Characteristics

- Can only measure small displacements.
- Conditioning circuits might be more troublesome.

Linear Variable Differential Transformer (LVDT)

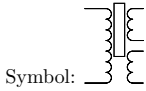

Construction:

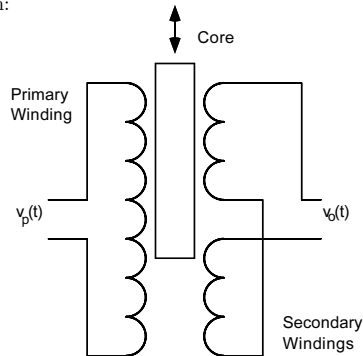

- A three-winding transformer with a movable core.
- Primary winding runs length of transformer.
- Each secondary covers one half of transformer.
- Secondaries are connected to oppose each other.
- Object is connected to core.

Principle of Operation

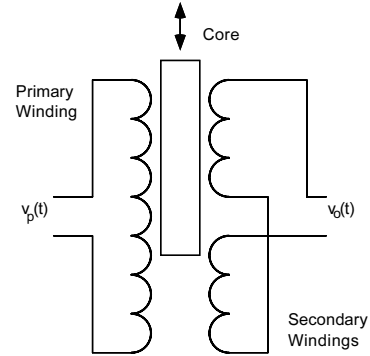

- When core is centered ...
- ... voltage at two secondaries are equal.
- Because they are connected in opposition ...
- ... voltages cancel ...
- ... and so output is zero.
- When core is off center ...
- ... voltage at one secondary ...
- ... is higher than at other.
- Output voltage is linearly related to core position.

Model Function

$$H_{v1}(x, t) = Kxv_p(t), \dots$$

... where K is a constant, $v_p(t)$ is the voltage at the primary winding, and t is time.

Note, if x is negative then phase of output is reversed.

In Typical LVDTs:

- The primary voltage can range from 1 to 10 V.
- Frequency from 50 Hz to 25 kHz can be used for primary winding.

Desirable Characteristics

- Low wear.
- High speed, can measure vibrations.
- Can measure small displacements, < 0.1 nm.
(Precision determined by conditioning circuit.)
- Low repeatability error.

Undesirable Characteristics

- Complex conditioning circuit needed.
- Expensive.

Coded Displacement Transducers (CDT)

These can be either:

- *Relative.*
Transducer indicates *change* in position, not actual position.
- *Absolute.*
Transducer indicates actual position.

They can measure:

- *Linear displacement.*
Position along a line.
- *Angular displacement.*
Angular position.

A generic CDT will be described, then the various types.

Coded Displacement Transducers—General Description

Physical Construction:

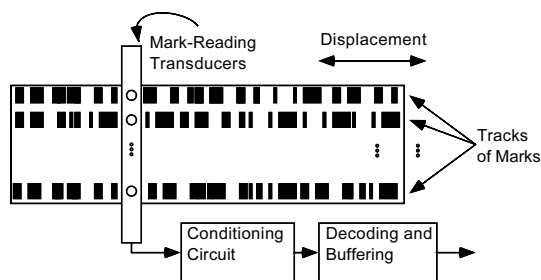

A strip or disk of some material, such as plastic, is mounted on object or on something linked to the object.

Strip or disk has marks in one or more tracks or rings.

Transducers, which can read the marks, are mounted in a fixed position.

A variety of transducers can be used to measure the marks.

Output of transducers is converted into a digital form.

Symbols d_i will denote the digital form of the transducer output.

The strip or disk is usually in a sealed package, to keep dirt out.

CDTs differ in the number of tracks and how the marks are placed.

Relative One-Way Angular Coded Displacement Transducers

Use: measurement of angle in systems limited to one-way rotation.

Marking

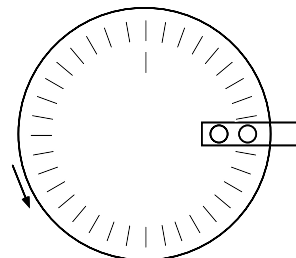

Two rings are used, *position* and *index*.

There are many marks on the position ring, regularly spaced.

Call signal from position ring d_p .

There is a single mark on the index ring.

Call signal from the index ring d_i .

Conditioning

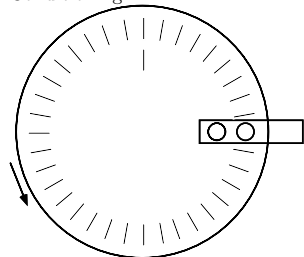

A counter is used.

Output d_p increments the counter, and d_i resets the counter.

Further processing may be done to get the output in the desired form, for example radians.

Model Function

This includes both the CDT and the counter.

$$H_{t1}(x) = \frac{x}{2\pi \text{ rad}} N, \text{ where } N \text{ is the number of position-ring marks.}$$

Note that the output is incorrect ...

... from power-on ...

... until the sensing of the index mark.

Example of Relative One-Way Angular CDT

Design a system to convert process variable $x \in [0 \text{ rad}, 2\pi \text{ rad}]$, the rotation angle of wheel, to a floating point quantity, $H(x) = x/\text{rad}$, to be written in variable **theta**. The wheel will rotate in only one direction. The precision must be at least 0.001 rad.

Solution

Use a relative one-way angular CDT.

Link the CDT disk to the wheel ...

... so that one turn of the wheel results in one turn of the CDT.

(It would also have been possible to put the marks directly on the wheel, but this might have been less convenient.)

Need at least 6284 marks.

Assume an $N = 10,000$ -mark CDT is available.

Then a $\lceil \log_2 N \rceil = \lceil \log_2 10000 \rceil = 14$ -bit counter is needed.

$$\text{Using these, } H_{t1}(x) = \frac{x}{2\pi \text{ rad}} 10000.$$

$$\text{Need } H_f(H_{t1}(x)) = H(x).$$

$$\text{Let } r = H_{t1}(x) = \frac{x}{2\pi \text{ rad}} N; \text{ solving, } x = \frac{2\pi \text{ rad}}{N} r.$$

$$\text{Then } H_f(r) = H\left(\frac{2\pi \text{ rad}}{N} r\right) = \frac{2\pi}{N} r.$$

$$\boxed{\text{theta} = r * 0.000628319;}$$

Relative Two-Way Coded Displacement Transducers

Use: measurement of angle or linear displacement in systems in which displacement will frequently be equal to some value (e.g., 0).

Marking

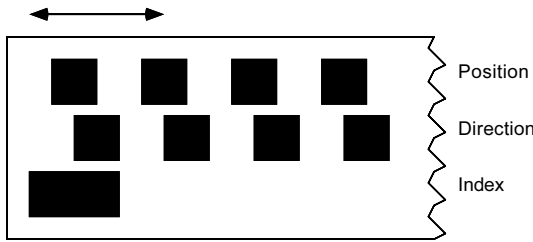

Description is for linear CDT; angular CDT is similar.

Three tracks are used, *position*, *direction*, and *index*.

Call the signal from the position track d_p , direction track d_d , and index track d_i .

There are many marks on the position and direction tracks, regularly spaced.

Position and direction tracks partially overlap.

When d_p makes a 0 to 1 transition, d_d gives the direction of travel.

There is a single mark on the index track.

Conditioning

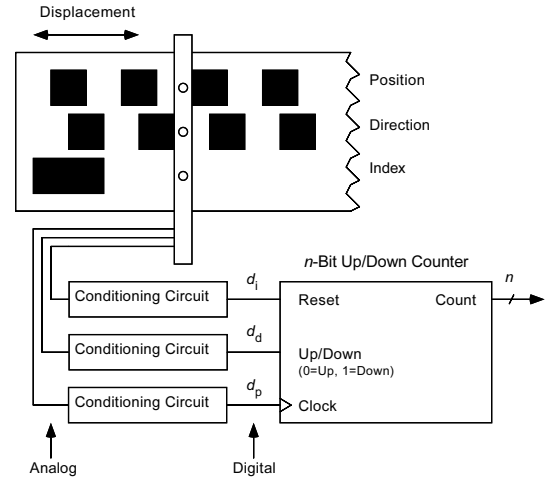

An up/down counter is used.

Output d_p clocks the counter and d_d determines the direction of count.

As in the one-way CDT, d_i resets the counter.

Further processing may be done to get the output in the desired form, for example radians.

Absolute Binary-Coded Displacement Transducers

Use: measurement of linear or angular position.

Marking

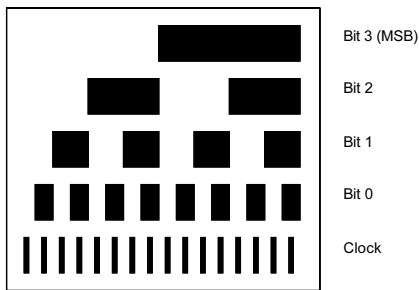

For an n -bit precision device, $n + 1$ tracks or rings are used.

One track is called the *clock* track, the others are called *position* tracks.

There are 2^n clock marks, spaced regularly.

Call signal from clock track d_ϕ and the signal from the i 'th position track d_i .

Let ϵ be the largest distance (in the direction of displacement) between transducers. (In an ideal system, $\epsilon = 0$).

Marks are positioned so that at position $x \pm \epsilon$,

if there is a transition in d_ϕ then there is no transition in any d_i .

As one might expect, the d_i give the position in binary.

Conditioning

An n -bit register is used.

The d_i connect to the register's data inputs.

The register is clocked with d_ϕ .

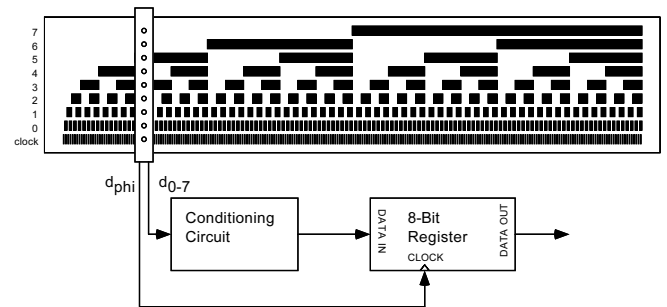

Purpose of Clock Marks

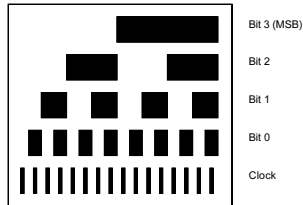

Consider a system in which there were no clock marks.

Output would be conditioned transducer signals, d_i , rather than register output.

Only n tracks would be needed for 2^n distinct positions.

This won't work. Consider a change from position 7 to 8:

Before: $d = 0111_2$. After: $d = 1000_2$.

Either all mark-reading transducers change at the same instant,

or $d \in \{0000, 0001, 0010, 0011, 0100, 0101, 0110, 1001, 1010, 1011, 1100, 1101, 1110, 1111\}$ in the moments between.

Why Binary?

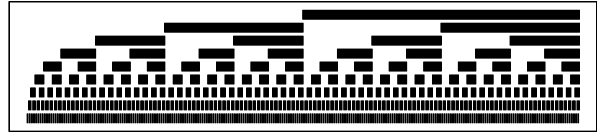

Other (not 100% serious) possibilities:

- *Binary-coded decimal*.
- *Seven-segment display*. Output can be fed to seven-segment displays.
- *ASCII numerals*. (E.g., 123). Read the number into a computer without ever having to do a binary conversion.
- *ASCII words*. (E.g., One hundred twenty three.). It can be done, but who would buy it?

The cost of a CBT is proportional to the number of tracks.

Binary is good because the minimum number of tracks are used, plus one.

Absolute Gray-Coded Displacement Transducers

Use: measurement of linear or angular position.

Marking

For an n -bit precision device, n tracks or rings are used.

All tracks are called *position* tracks.

Call signal from the i 'th position track d_i .

As one might expect, the d_i give the position in gray code.

Gray Code Properties

Gray-coded number: sequence of zeros and ones (like binary).

Let a be a nonnegative integer.

Gray-code for a differs from gray-code for $a + 1$ in *exactly one digit*.

Therefore, in CDT using gray code, only 1 transducer's output will change at a time—no races.

Gray Code Definition

Gray code is defined for non-negative integers.

Let $B \in [0, 2^n)$. (That is, B is any number from 0 to $2^n - 1$.)

Let b_i be digit i in B 's binary representation, for $i \in [0, n)$. (The least-significant digit is b_0 .)

Symbol g_i is digit i in B 's gray-code representation if

$$g_{n-1} = b_{n-1} \quad \text{and} \quad g_i = b_{i+1} \oplus b_i, \quad \text{for } i \in [0, n-1).$$

Symbol b_i is digit i in B 's binary representation if

$$b_{n-1} = g_{n-1} \quad \text{and} \quad b_i = b_{i+1} \oplus g_i, \quad \text{for } i \in [0, n-1).$$

Gray Code Examples

Four Bits

7 (decimal) = 0111 (binary) = 0100 (gray)

8 (decimal) = 1000 (binary) = 1100 (gray)

Five Bits

11 (decimal) = 01011 (binary) = 01110 (gray)

12 (decimal) = 01100 (binary) = 01010 (gray)

13 (decimal) = 01101 (binary) = 01011 (gray)

14 (decimal) = 01110 (binary) = 01001 (gray)

Twenty Bits

123,456 (decimal)

=0001 1110 0010 0100 0000 (binary)

=0001 0001 0011 0110 0000 (gray).

Gray- and Binary-Coded Displacement Transducers

Four-Bit Binary and Gray:

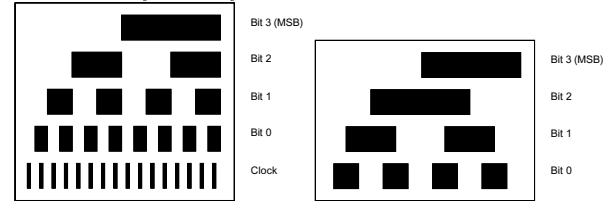

Eight-Bit Binary:

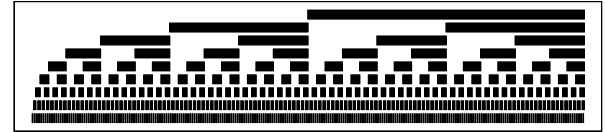

Nine-Bit Gray:

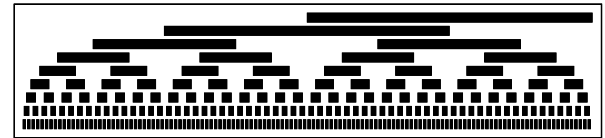

Coded Displacement Transducers Characteristics

Desirable Characteristics

- Linear (or any other response needed).
- Accurate and precise.
Strip or disk can have 65536 or more marks per track or ring.
- Low wear.
- Simple conditioning circuit.

Undesirable Characteristics

- Contact with object required, or object must have marks.

Form of Marks

Ink on a ceramic or glass substrate.

Holes in some material. (Read optically or mechanically.)

Current-conducting ink on an insulating substrate.

Proximity Transducers

Detect when an object is near.

Types of Transducers

- *Reed switch.*
Switch closed by magnet on object.
- *Hall effect.*
Magnetic field from object induces a potential ...
... on a block of semiconductor.
- *Magnetic reluctance.*
An object passes through a magnetic field...
... inducing a voltage in a coil.

Plus many more, not covered.

No conditioning circuits will be given for the proximity transducers.

Reed Switch

Construction and Operation:

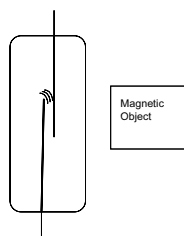

Small glass tube with two switch contacts.

Magnet pulls switch contacts closed.

As with all switches, it does not go from open to closed neatly. (When closing, it might go from open to closed many times before settling into a closed state.)

Conditioning Circuit

Output might have to be “debounced” (low-pass filtered).

Desirable Characteristic

- Cheap.

Undesirable Characteristics

- Low speed.
- Limited life.

Hall-Effect Proximity Sensor

Construction and Operation

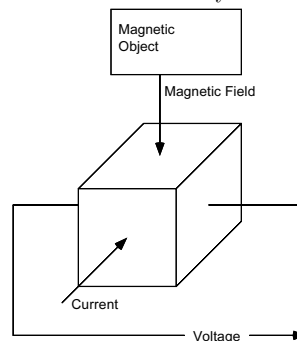

Consists of a block of semiconductor material. There is no PN junction.

The object detected must produce a magnetic field.

If it's not naturally magnetic and you can't glue a magnet to it, you can't use a hall-effect transducer.

Consider the three axes normal to the block's faces.

A constant current is passed along one axis.

The transducer is positioned so that the magnetic field from the object is parallel to a second axis.

And, voilà, a potential is induced on the faces normal to the third axis.

Contacts on these faces connect to leads.

The output of the transducer is the voltage.

Magnetic Reluctance Transducer

Construction and Operation

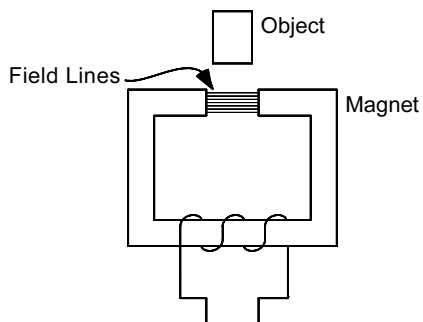

Consists of a coil of wire wrapped around a c-shaped magnetic core.

Magnetic field lines pass through gap in core.

Object passes through the gap.

This changes the strength of the magnetic field which...

induces a voltage in the coil ends.

Voltage is proportional to rate of change of field strength.

Other Proximity Transducers

Many ways of building these.

Type depends upon what is being detected and where it is being detected.

Broken light beam.

Radiated heat.

Sound.

⋮