

Strain, Force, and Pressure

Force is that which results in acceleration (when forces don't cancel).

Strain is the change in shape of an object . . .

. . . usually due to some force.

(Force is usually called stress in this context.)

Pressure is force per unit area.

Strain

Consider an object in two situations: with and without a force applied.

Let a force be applied along a dimension.

Let L_1 be the length of the object along the dimension when no force is applied.

Let L_2 be the length when the force is applied.

Then the object's strain is defined to be $\frac{L_2 - L_1}{L_1}$.

The symbol ϵ is usually used to denote strain.

In most situations, strains of interest will be very small, $|\epsilon| < 0.0001$.

Strain Transducers

Called *strain gauges*.

Symbol: no common symbol.

Construction

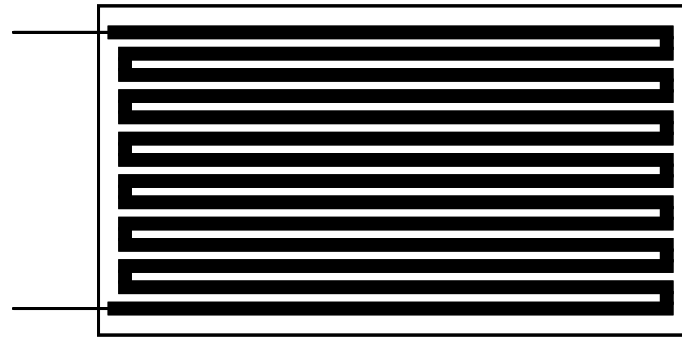

Flexible card with strip of some conductor arranged in special pattern.

Card is mounted (glued) onto the object being measured.

Conductor is usually a metal or semiconductor.

Pattern is chosen so that strain (to be measured) ...
... occurs along direction of current flow.

Current is passed through conductor.

Principle of Operation For Both Types

Conductor maintains an almost constant volume with strain.

That is, conductor is not compressible.

Recall that the resistance of a conductor is $R = \rho \frac{L}{A}$, where

L is its length,

A is its area, and

ρ is its resistivity.

Suppose force causes length of the conductor to decrease.

Since volume does not change much, area must increase.

Thus, resistance decreases.

Model Function

$$H_{t1}(x) = R_0(1 + G_f x),$$

where G_f is a constant ...

... called the *gauge factor*.

For metal strain gauges, $G_f = 2$.

(An integer!)

For semiconductor strain gauges G_f is much higher.

Complementary Pairs

In some cases the strain ...
... in two places on the object ...
... will be of equal magnitude—but opposite sign.

For example, a cantilever beam:

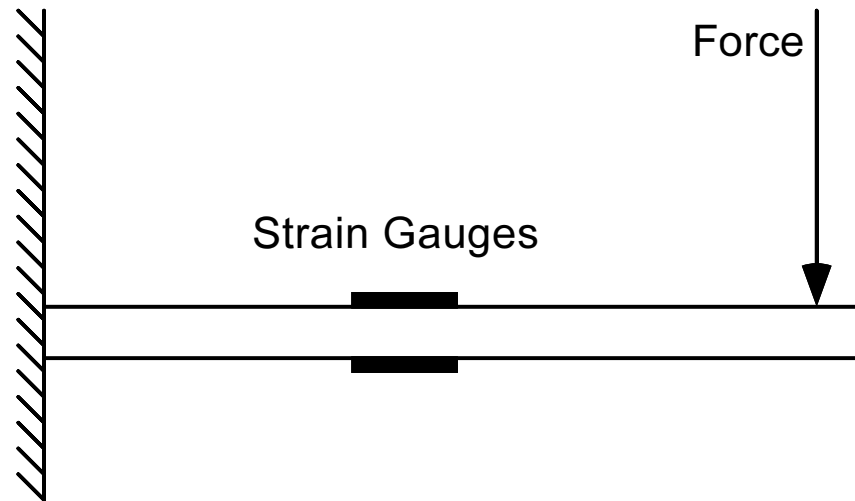

The upper part of beam is stretched (positive strain) ...
... and the lower part of beam is compressed (negative strain).

The two strain gauges therefore ...
... form complementary pairs.

Derivation of Gauge Factor for Ideal Metal

Ideal metal's properties:

- Non-compressible. (Does not change volume.)
- Resistivity is constant.

Consider an Ideal Metal Block

Regardless of strain:

volume is S and resistivity is ρ .

When unstrained:

call length L_1 , area A_1 , and resistance R_1 .

By standard resistivity formula,

$$R_1 = \rho \frac{L_1}{A_1}.$$

Since volume fixed,

$$A_1 = S/L_1.$$

Resistance can be found in terms of length and area:

$$R_1 = \rho \frac{L_1^2}{S}.$$

The Block Suffering Strain ϵ

Call new length L_2 .

By definition of strain,

$$L_2 = L_1(1 + \epsilon).$$

Resistance in terms of R_1 and ϵ :

$$\begin{aligned} R_2 &= \rho \frac{L_2}{A_2} \\ &= \rho \frac{L_2^2}{S} \\ &= \rho \frac{(L_1(1 + \epsilon))^2}{S} \\ &= \rho \frac{L_1^2(1 + \epsilon)^2}{S} \\ &= R_1(1 + \epsilon)^2 \\ &= R_1(1 + 2\epsilon + \epsilon^2) \\ &\approx R_1(1 + 2\epsilon) \end{aligned}$$

When ϵ is small simplified form close to the exact form.

Effect of Temperature

Physically, a strain gauge is not much different from an RTD ...
... and so, alas, strain gauge affected by temperature ...
... therefore temperature compensation needed.

Model function including temperature:

$$H_{t1}(x) = R_0(T)(1 + G_f x),$$

where resistance $R_0(T)$ is a function of temperature.

Conditioning circuit must “remove” $R_0(T)$ term.

A bridge does this very well.

Typical Strain Gauge Conditioning Circuit

Consider model function including temperature effect:

$$H_{t1}(x) = R_0(T)(1 \pm G_f x),$$

(Note that the complementary pair is indicated here by a \pm .)

Four strain gauges are placed in the bridge in the following way:

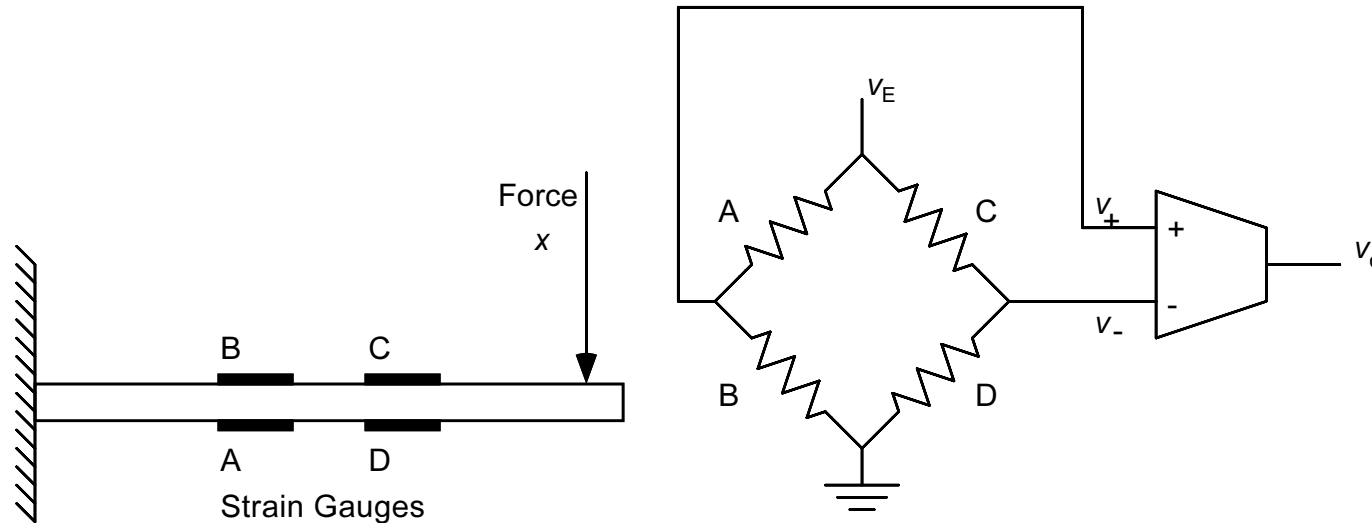

The temperature terms cancel, so:

$$v_o = Av_E G_f x.$$

Force

Definition: that which causes a mass to accelerate, $\vec{F} = m\vec{a}$.

Units: Newton, $1 \text{ N} \equiv \frac{\text{kg}}{\text{m/s}^2}$; dyne, $1 \text{ dy} \equiv \frac{\text{g}}{\text{cm/s}^2}$; pound, etc.

Types of Transducers

- *Small displacement.*

Force bends, compresses, or stretches a part of the transducer.

Change in shape usually measured using strain gauges.

- *Large displacement.*

Force moves a part of the transducer.

Movement measured using displacement sensors.

- *Piezoelectric crystals.*

Based on a material that emits charge when compressed.

Small-Displacement

Also called *load cells*.

Typical construction:

Consists of a rigid framework,
for example a cantilever beam.

The force is applied at a predetermined point.

Strain gauges are placed ...

... at locations chosen so that ...

... their output is linearly related to force.

The choice of location for the strain gauges ...

... and the derivation of the resulting load-cell model function ...

... is beyond the scope of this course.

Load cells usually packaged ...

... with strain gauges connected in bridge configuration.

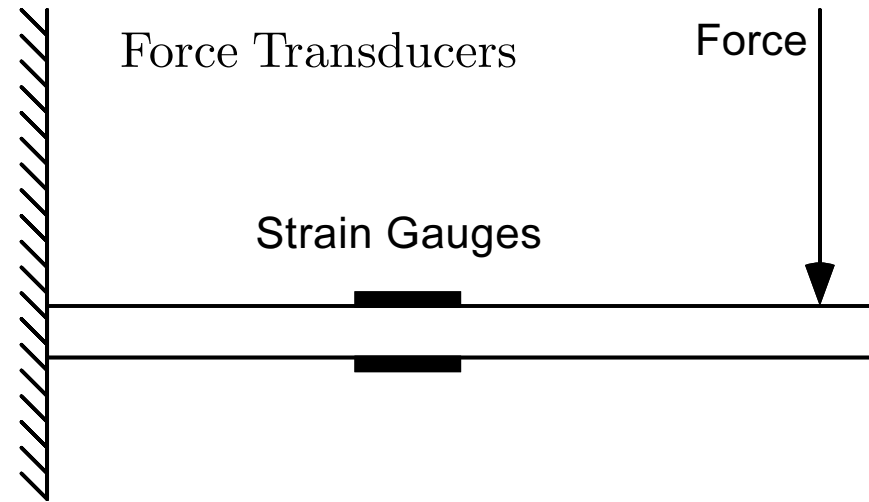

Two other common load-cell configurations are illustrated below:

Load Cell Model Function

Load cells, as sold, usually include a bridge circuit.

Therefore the bridge excitation voltage, v_E , will appear in the model function.

$H_{t1}(x) = x k v_E$, where k is a constant.

Desirable Characteristic

Accurate.

Undesirable Characteristic

Expensive.

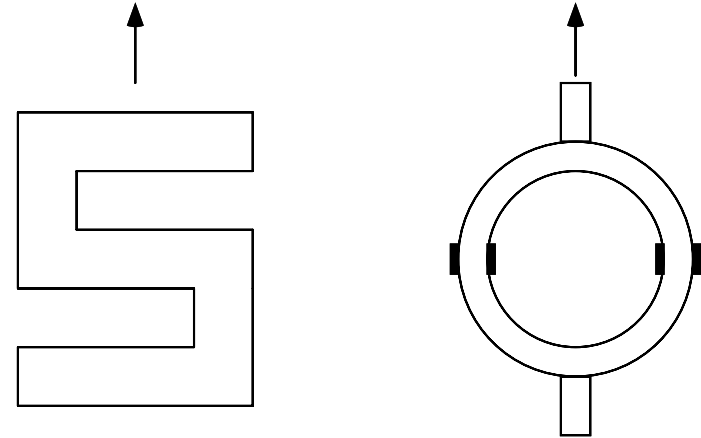

Large-Displacement Force Transducers

Typical construction and principle of operation:

Consists of a flexible structure.

The force is applied at a predetermined point.

Force causes structure to flex, this measured by a displacement transducer.

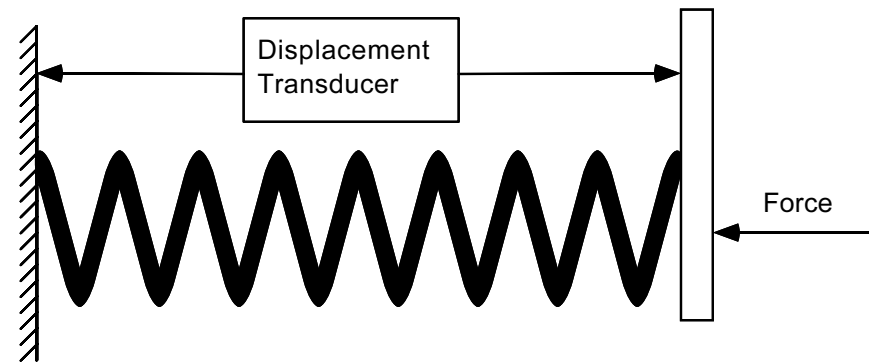

Structure chosen so that displacement is linearly related to force.

The design of this part is within the scope of the course.

One candidate for the flexible structure is, of course, a spring.

Undesirable Characteristics

Requires a large displacement. May not be practical in all systems. (For example, a bathroom scale.)

Higher calibration and repeatability error than small-displacement transducers.

Desirable Characteristic

Inexpensive.

Ideal Springs

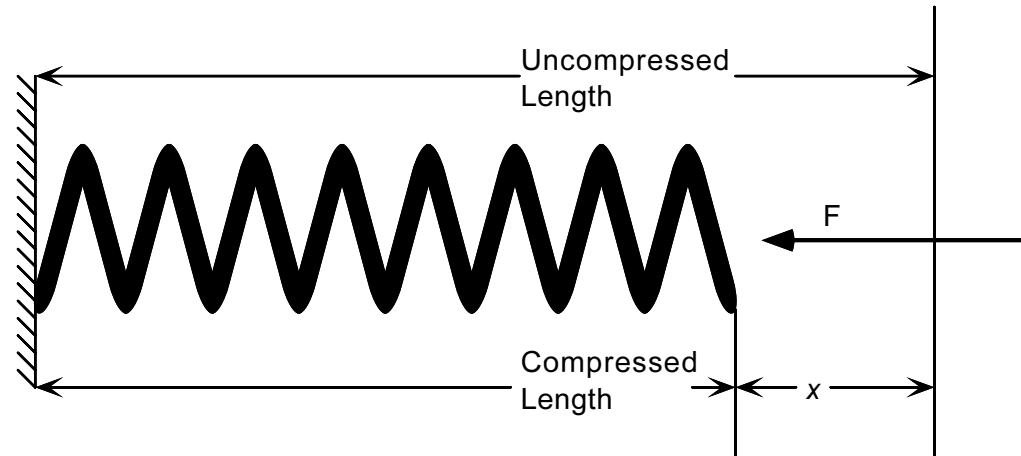

One end of spring mounted to a fixed point.

Force applied to other end.

Ideal springs obey Hooke's Law: $F = -kx$,
where x is the displacement,
 F is the force, and
 k is the *force constant* for the spring.

In this class, all springs will be ideal. (When used as directed.)

Large-Displacement Force Transducer Sample Problem

Design a system to convert process variable $x \in [0 \text{ N}, 33 \text{ N}]$ to a floating point number, $H(x) = x \frac{1}{\text{N}}$, to be written into variable **force**. The precision must be at least $\pm 0.5 \text{ N}$.

Solution:

Use a large-displacement force transducer consisting of a spring with $k = 1 \frac{\text{N}}{\text{mm}}$.

Use a coded displacement sensor to measure spring displacement.

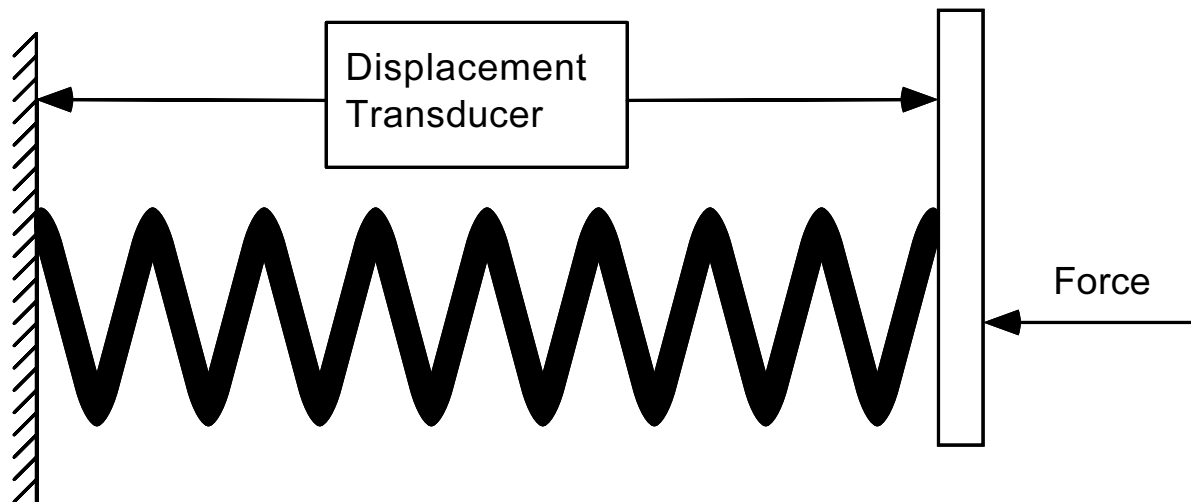

Number of distinct forces to measure at least $33/.5 + 1 = 67$. Therefore, use a 7-bit binary coded-displacement transducer.

Spring displacement range: $[0, 33 \text{ mm}]$. Choose CDT which matches this range.

Combined response of spring and CDT: $H_{tc}(x) = \left\lfloor \frac{x}{33 \text{ N}} 127 \right\rfloor$.

Interface-routine code:

```
raw = readInterface();
```

```
force = raw * 0.2598;
```

Piezoelectric Crystals

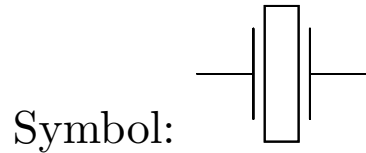

Construction and Operation

Consists of a crystal of a material with piezoelectric properties.

Material can be quartz, or special ceramics.

Contacts are placed along two faces of crystal.

Pressure is applied to the crystal.

Charge appears on the surface of the crystal, proportional to the force.

Model Function

$H_{t1}(x) = kx$, where k is a constant with dimensions charge per pressure.

That is, the output of the transducer is charge.

Typical Conditioning Circuit

The output of the crystal converted to voltage using a capacitor.

Recall, $V = \frac{Q}{C}$.

Capacitor chosen to get desired voltage range.

Very high input impedance amplifier needed.

Because of leakage ...

- ... through capacitor, amplifier, etc. ...
- ... even when an unchanging force is applied ...
- ... voltage will decrease over time.

Therefore, piezoelectric crystals best used ...

- ... for measuring *changes* in force ...
- ... *exempli gratia*, vibration.

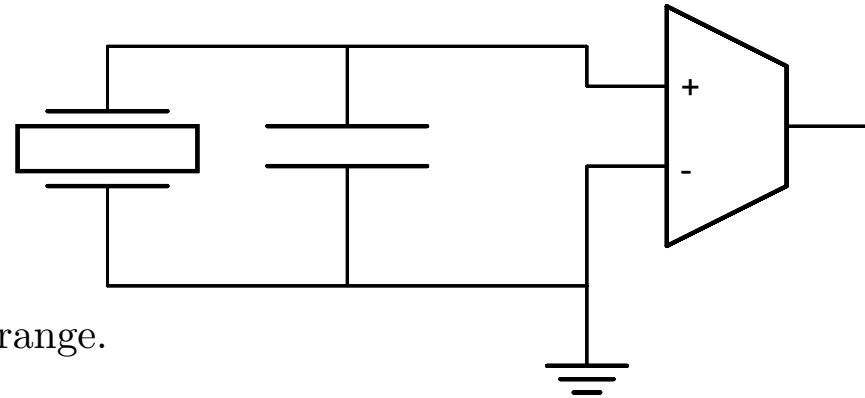

Pressure

Definition: force per unit area.

Here, only pressure exerted by fluids (liquids, gases, and solids under certain conditions) will be considered.

Common units,

$$\text{Pascal} \left(1 \text{ Pa} = 1 \frac{\text{N}}{\text{m}^2} \right),$$

kilopascal (kPa),

mm Hg,

bar,

pound per square inch.

Types of Pressure Transducers

- *Large-Displacement Transducers.*

These consists of a variety of flexible containers that change size with pressure.

- *Small-Displacement Transducers.*

These usually consist of a diaphragm and a strain gauge.

Types of Pressure

Pressure usually specified as a difference between the process variable measured and some reference pressure.

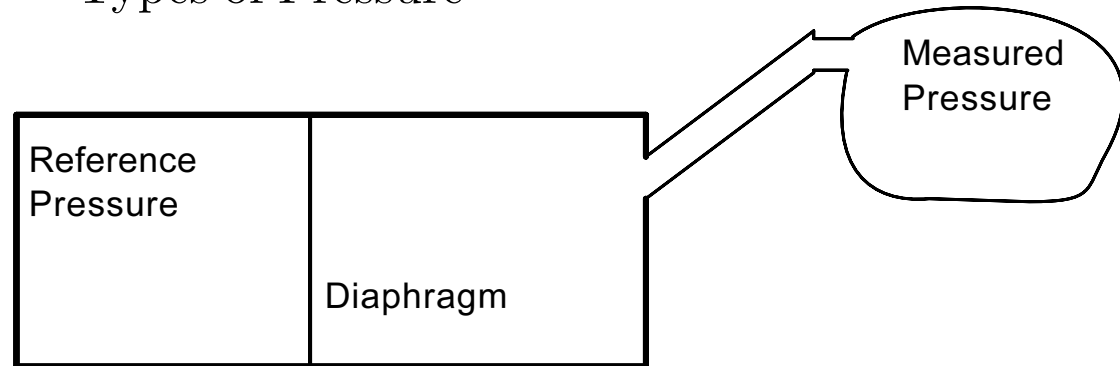

This can be visualized as the pressure on a diaphragm, with the pressure being measured on one side and the reference pressure on the other.

That reference pressure determines (defines) the type of pressure measured:

- *Absolute*. Reference pressure is zero.
- *Gauge*. Reference pressure is the environment air pressure.

Automobile tire pressure is gauge pressure. (A zero on your pressure gauge measured from a flat tire does not mean there is a vacuum inside the tire. Instead it means the pressure is the same inside and outside the tire.)

- *Differential*. The reference pressure is a second process variable being measured.

Large-Displacement Pressure Transducers

Construction and Operation:

Key part is a flexible container.

Inside of flexible container is exposed to the pressure.

Outside of flexible container is exposed to reference pressure.

Size of container changes with pressure.

Size is measured by displacement transducer.

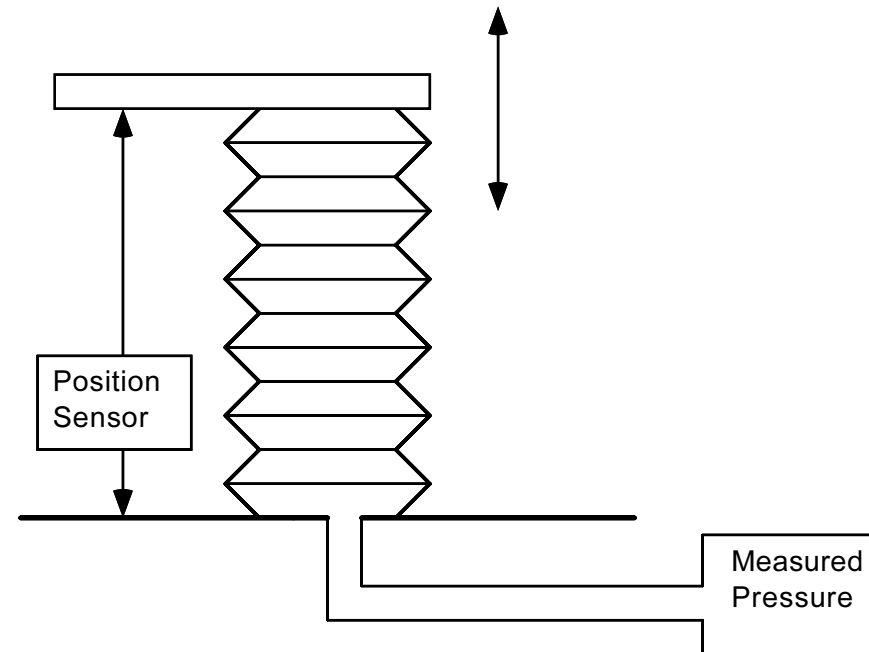

Desirable Characteristic

Inexpensive.

Undesirable Characteristic

High calibration and repeatability errors.

Small-Displacement Pressure Transducers

Construction and Operation:

Consists of a diaphragm, one side exposed to pressure being measured.

Other side exposed to reference pressure.

Either:

Displacement of diaphragm measured by capacitive or inductive displacement transducer.

Or strain of diaphragm measured using strain gauges.

Placement of Strain Gauges

Center of diaphragm convex, part near edge is convex.

Strain gauges can be placed so that there are complementary pairs.

Diaphragm, Top View

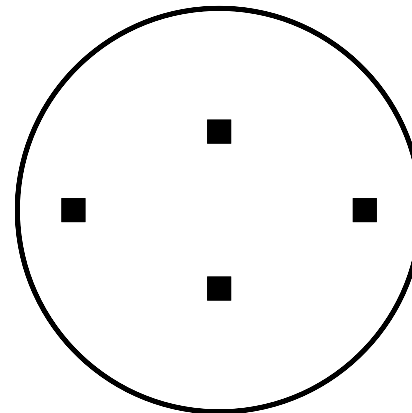

Diaphragm, Side View



Integrated Pressure Sensors

Uses a small-displacement pressure transducer.

Entire sensor is fabricated on one silicon chip.

Diaphragm is etched into silicon.

Strain gauges are fabricated on silicon.

Conditioning circuit on same chip.