

Definition: The translational (*e.g.*, wiggling around) energy ...
... of particles in a system.

No practical way to measure ...
... velocity of every particle ...
... in most systems of interest.

Instead, *temperature scales* are defined.

There are two types:

- The *thermodynamic temperature scale*.
“Really” measures temperature.
- *Practical temperature scales*.
Approximations of thermodynamic scale.

Much easier to measure temperature on a practical scale.

For temperatures of interest, differences are very small.

Kelvin's Thermodynamic Temperature Scale

Due to William Thomson, a.k.a., Lord Kelvin (1824-1907).

Start with a precise temperature that can easily be reproduced.

The *triple point* of water, T_{tr} , is used.

T_{tr} is temperature at which ...

... water can simultaneously be in ...

... the solid, liquid, and gas states: 0.01 °C.

- Confine an ideal gas in a container of fixed volume, S .
- Bring the gas to temperature T_{tr} .

Call the pressure of this gas P_{tr} .

By definition (of the Kelvin scale) this temperature is $T_{\text{tr}} \triangleq 273.16 \text{ K}$.

The ideal gas law: $PS = n\mathfrak{R}T$.

Substituting, $P_{\text{tr}}S = n\mathfrak{R}273.16 \text{ K}$. Then $n\mathfrak{R} = \frac{P_{\text{tr}}S}{273.16 \text{ K}}$.

- Bring the same system to another temperature, T .

Call the pressure at this temperature, P .

Solving for T in the gas law: $T = \frac{PS}{n\mathfrak{R}}$.

Substituting for $n\mathfrak{R}$ using the quantity obtained above yields

$$T = PS \frac{273.16 \text{ K}}{P_{\text{tr}}S} = 273.16 \text{ K} \frac{P}{P_{\text{tr}}}.$$

Practical Temperature Scales

Designed to be easy (relatively) to measure.

Scales are revised every few decades.

Latest revision in 1990, called ITS-90.
(International Temperature Scale.)

Older scale (1968), IPTS-68.
(International Practical Temperature Scale)

Difference between ITS-90 and IPTS-68 ...
... is as large as 0.4°C at 800°C .

At human-tolerable temperatures, ...
... difference is in hundredths of a degree.

All practical scales are identical at the triple point of water.

How a practical temperature scale is defined:

A set of fixed points is established, ...
... for example the triple point of water.

A temperature is assigned to each fixed point, ...
... based on the thermodynamic scale.

Accurate thermometers (transducers) are chosen.

Functions are defined mapping ...
... the thermometers' output to temperature ...
... so that they pass through the fixed points.

⇒ Temperatures defined in terms of fixed points and special transducers.

For ITS-90:

- (.65 K, 5.0 K)
Vapor-pressure relation between two isotopes of helium.
- (3.0 K, 24.5561 K)
Helium fixed-volume thermometer.

(Like thermometer used in thermodynamic scale, ...
... except helium replaces the ideal gas.)
- (13.8033 K, 1234.93 K)
Resistance of platinum.
- > 1234.93 K:
Based on radiated light.

Basic Types

- *Thermistor.*
Block of semiconductor material.

Resistance is a function of temperature.
- *Resistance Temperature Device (RTD)*
Strip of metal.

Resistance is a function of temperature.
- *Thermocouple.*
Potential across two metals is a function of temperature.
- *Diode.*
Forward-bias voltage is a function of temperature. (Not covered.)

Integrated Temperature Sensors

Transducer and factory-calibrated conditioning circuit ...

... combined in a single package.

Usually available as current or voltage sources.

Current or voltage is a convenient, linear function of temperature.

Name: Thermal resistor.

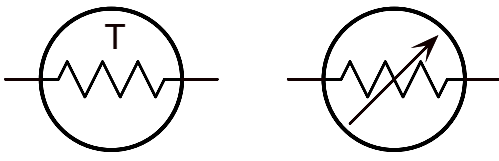
Symbols:  (Both are used.)

Temperature range: about -100°C to 200°C . (Relatively narrow.)

Construction:

block of semiconductor material (without junction).

Principle of Operation

As with all semiconductors,...

... electron energy levels divided into two bands,...

... *valence* and *conduction*.

Electrons in conduction band participate in current flow.

Electrons in valence band do not.¹

The number of electrons in conduction band...

... increases with temperature, ...

... reducing resistance.

Resistance is determined by the density of conduction electrons.

¹ Actually they do, but that's a hole other story.

Desirable Characteristics

- Sensitive.
(Small change in temperature yields an easily readable change in resistance.)
- Can be made very small.
(Small devices react to temperature changes quickly.)
- High resistance.
(Easier to design conditioning circuit.)

Undesirable Characteristics

- Delicate.
Can be damaged (de-calibrated) by excessive heat.
- There are many non-standard types.

Transducer Model Functions

All functions will be approximations.

Very good, the Steinhart-Hart Equation:

$$H_{t1}^{-1}(y) = \left(\frac{1}{A + B \ln y + C \ln^3 y} \right)^{-1},$$

where A , B , and C , are experimentally determined constants.

Good: $H_{t2}(x) = R_0 e^{\frac{\beta}{x}}$.

Later, a linear function will be derived.

Convert process variable $x \in [-10^\circ\text{C}, 50^\circ\text{C}]$, the temperature in room 102 EE Building into $H(x) = x \frac{1}{\text{K}}$, a floating-point number. The number should have a precision of 0.05. Use a thermistor and the function $H_{t2}(x) = R_0 e^{\frac{\beta}{x}}$ with $\beta = 3000 \text{ K}$ and $R_0 = 0.059 \Omega$.

Solution Plan:

- Choose ADC.
- Based on ADC input voltage, design conditioning circuit.
- Based on ADC precision (bits), write interface routine.

ADC Choice

Use ADC with function $H_{\text{ADC}(5 \text{ V}, b)}(y) \dots$

\dots value of b chosen later.

Conditioning Circuit

Input is a resistance (from thermistor), output is voltage.

Input range to ADC is 0 to 5 V, therefore:

$$0 \leq H_c(H_{t2}(x)) \leq 5 \text{ V} \quad \text{for } -10^\circ\text{C} \leq x \leq 50^\circ\text{C}$$

Choose conditioning circuit based on this constraint.

Conditioning circuit will not linearize x .

(This would be very difficult using analog circuits.)

Thermistor $y = H_{t2}(x)$ is monotonic with temperature.

In this case, when x increases y always decreases.

Therefore, conditioning circuit must convert either:

$$H_{t2}(-10^\circ\text{C}) = 0 \text{ V} \quad \text{and} \quad H_{t2}(50^\circ\text{C}) = 5 \text{ V}$$

or

$$H_{t2}(-10^\circ\text{C}) = 5 \text{ V} \quad \text{and} \quad H_{t2}(50^\circ\text{C}) = 0 \text{ V}.$$

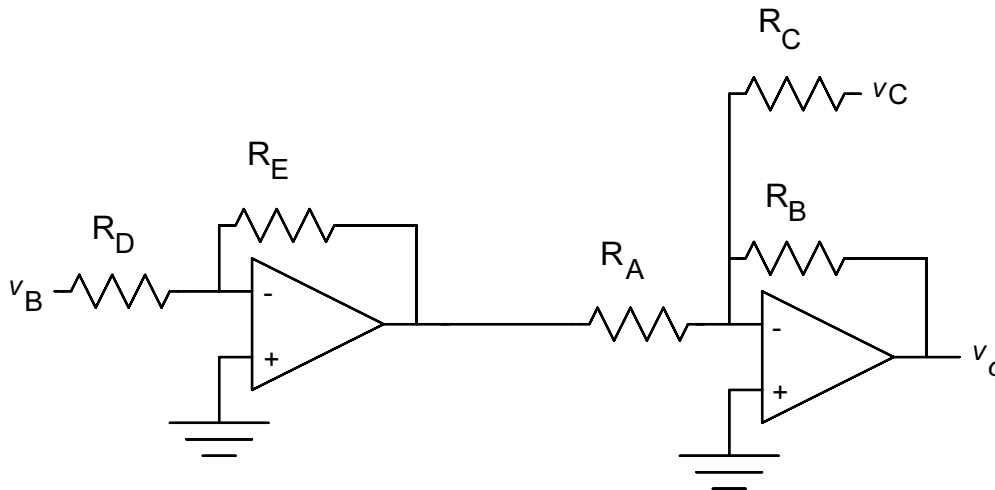

Will use gain/offset circuit.

Let $R_{\max} = H_{t2}(263.15 \text{ K}) = 5272 \Omega$ and
 $R_{\min} = H_{t2}(323.15 \text{ K}) = 634.9 \Omega$.

$$H_c(H_{t2}(50^\circ \text{C})) = H_c(R_{\min}) = A_5(R_{\min} - O_5) = 0 \text{ V}$$

$$H_c(H_{t2}(-10^\circ \text{C})) = H_c(R_{\max}) = A_5(R_{\max} - O_5) = 5 \text{ V}$$

Therefore, $O_5 = R_{\min}$ and $A_5 = \frac{5 \text{ V}}{R_{\max} - R_{\min}}$.

Recall $O_5 = \frac{v_C R_D R_A}{v_B R_C}$ and $A_5 = \frac{R_B v_B}{R_D R_A}$.

Suppose, the following are convenient values:

$$R_A = 1 \text{ k}\Omega, R_D = 5 \text{ k}\Omega, v_B = v_C = 10 \text{ V}.$$

Then choose $R_C = 7876 \Omega$ and $R_B = 539.2 \Omega$.

Then $A_5 = 1.078 \text{ mA}$ and $O_5 = 634.9 \Omega$. So:

$$H_c(y) = 1.078 \text{ mA}(y - 634.9 \Omega)$$

Problem specified that $H(x)$ should have a 0.05 precision.

ADC Output:

$$H_{\text{ADC}(v_{\text{ADC}},b)}(H_c(H_{t2}(x))) = z = \frac{1}{v_{\text{ADC}}}(2^b - 1)A_5(R_0e^{\beta/x} - O_5).$$

To determine precision evaluate at $x_1 = 323.10$ K and $x_2 = 323.15$ K.

Difference should be no less than one.

$$H_{\text{ADC}(v_{\text{ADC}},b)}(H_c(H_{t2}(x_1))) - H_{\text{ADC}(v_{\text{ADC}},b)}(H_c(H_{t2}(x_2))) \geq 1$$

$$\frac{1}{v_{\text{ADC}}}(2^b - 1)A_5(R_0e^{\beta/x_1} - R_0e^{\beta/x_2}) \geq 1$$

Solving for b yields:

$$b \geq \left\lceil \log_2 \left(\frac{v_{\text{ADC}}}{A_5(R_0e^{\beta/x_1} - R_0e^{\beta/x_2})} + 1 \right) \right\rceil = 13.$$

Interface Routine

$$H_{\text{ADC}(v_{\text{ADC}},b)}(H_c(H_{t2}(x))) = z = \frac{1}{v_{\text{ADC}}}(2^b - 1)A_5(R_0e^{\beta/x} - O_5).$$

Solving for x yields

$$x = \beta \left(\ln \left(\frac{O_5}{R_0} + \frac{1}{A_5 R_0} \frac{z v_{\text{ADC}}}{(2^b - 1)} \right) \right)^{-1}$$

$$H_f(H_{\text{ADC}(v_{\text{ADC}},b)}(H_c(H_{t2}(x)))) = H(x) = \frac{x}{K}.$$

$$H_f(z) = H(x) = \beta \left(\ln \left(\frac{O_5}{R_0} + \frac{1}{A_5 R_0} \frac{z v_{\text{ADC}}}{(2^b - 1)} \right) \right)^{-1} \frac{1}{K}.$$

Substituting values:

$$\text{tee} = 3000.0 / (\log(10760.3 + 9.5949 * \text{raw}));$$

where `raw` is the value read from the ADC output.

Linear transducer functions are preferred.

Especially useful when there is no computer processing.

Thermistor response is close to linear *over small temperature ranges*.
(But non-linear over wide temperature ranges.)

A linear thermistor function will be derived.

Plan:

Call T_M the “middle” temperature.
(Center of range of temperatures to measure.)

Goal: derive function in form $H_{t4}(x) = R_M(1 + \alpha\Delta x) \dots$
 \dots where R_M and α are constants to be determined \dots
 \dots and $\Delta x = x - T_M$.

Temporarily set $H_{t4}(x) = mx + b$, the equation of a straight line.

Let $m = \left(\frac{d}{dx} H_{t2}(x) \right) \Big|_{x=T_M}$.

Solve for b in $mT_M + b = H_{t2}(T_M)$.

Transform $mx + b$ into $R_M(1 + \alpha\Delta x)$. Then:

$$R_M = H_{t2}(T_M) = R_0 e^{\frac{\beta}{T_M}} \quad \text{and} \quad \alpha = -\frac{\beta}{T_M^2}$$

Note: derivation can also be done using a more accurate model than $H_{t2}(x)$.

Assuming the linear thermistor model, ...
... a gain/offset amplifier could...
... convert temperature linearly into voltage.

For example, $H(x) = \left(\frac{x}{\text{K}} - 300 \text{ K}\right) \text{ V}$, for $x \in [300, 301]$.

However, if a wide temperature range were used, ...
... model error would be unacceptably high.

Idea:

Place thermistor in a resistor network to achieve some linearity.

A simple but effective example appears below.

For convenience, combination will be treated as a transducer.

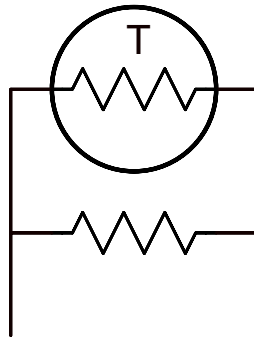

$$\text{Transfer function: } H_{t3}(x) = \frac{R_M}{2} \left(1 + \frac{\alpha}{2} \Delta x \right),$$

where R_M is resistance at center of range,

$$\Delta x = x - T_M,$$

T_M is the temperature at the center of range,

$$\text{and } \alpha = \frac{1}{R_M} \frac{d}{dx} H_t(x) \Big|_{x=T_M}.$$

How much more accurate is this?

Compute the model error of thermistor functions H_{t4} and H_{t3} at temperatures 250 K, 270 K, and 290 K for a thermistor and a thermistor with a shunt resistor (the passive conditioning circuit just presented) designed for temperature range [250 K, 290 K]. Base the error on the following measurements:

$$R_t(250 \text{ K}) = 9603 \Omega,$$

$$R_t(270 \text{ K}) = 3948 \Omega,$$

$$R_t(290 \text{ K}) = 1835 \Omega,$$

where $R_t(T)$ is the measured resistance of the thermistor at temperature T .

Thermistor model functions.

$$H_{t4}(x) = R_M(1 + \alpha(x - T_M)) \text{ and } H_{t3}(x) = \frac{R_M}{2} \left(1 + \frac{\alpha}{2}(x - T_M) \right),$$

where $T_M = 270 \text{ K}$, $\alpha = -\frac{\beta}{T_M^2} = \frac{-0.04115}{\text{K}}$ and $R_M = 3948 \Omega$.

The inverse of functions are:

$$H_{t4}^{-1}(R_{t4}) = \frac{1}{\alpha} \left(\frac{R_{t4}}{R_M} - 1 \right) + T_M \quad \text{and} \quad H_{t3}^{-1}(R_{t3}) = \frac{2}{\alpha} \left(2 \frac{R_{t3}}{R_M} - 1 \right) + T_M.$$

Ideal x / K	R_{t4} / Ω	R_{t3} / Ω	Actual $H_{t4}^{-1}(R_{t4}) / \text{K}$	Pct. Err.	Actual $H_{t3}^{-1}(R_{t3}) / \text{K}$	Pct. Err.
250	9603	2798	235.2	5.91%	249.7	0.10%
270	3948	1974	270.0	0	270.0	0
290	1835	1253	283.0	2.42%	287.7	0.78%

Plotted below are the actual temperature and the temperature computed using the two thermistor-model functions.

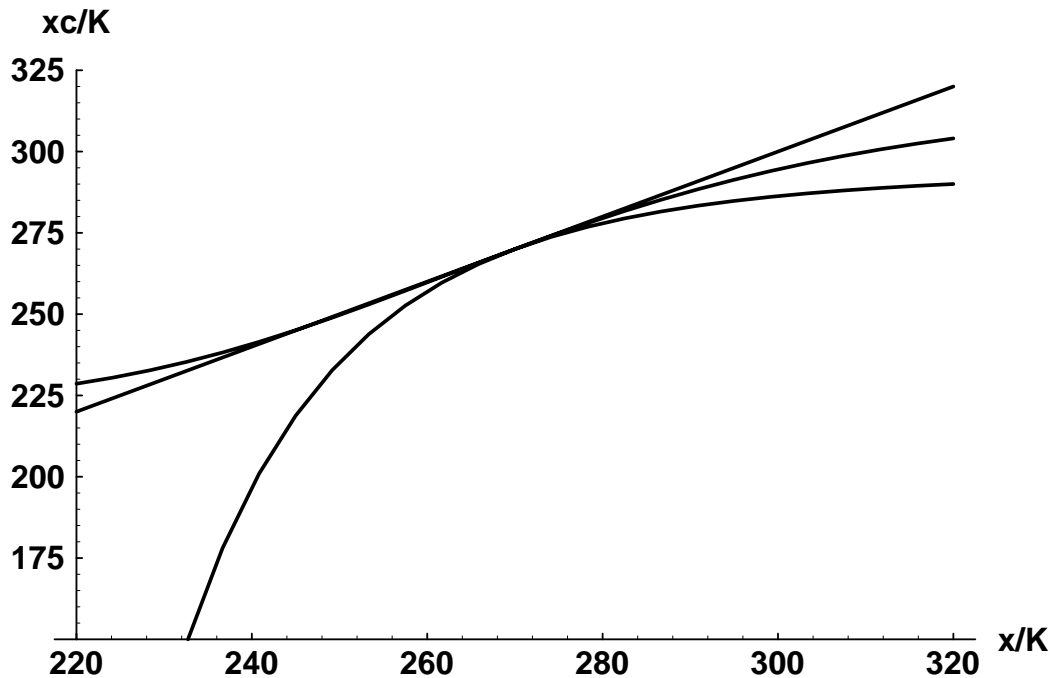
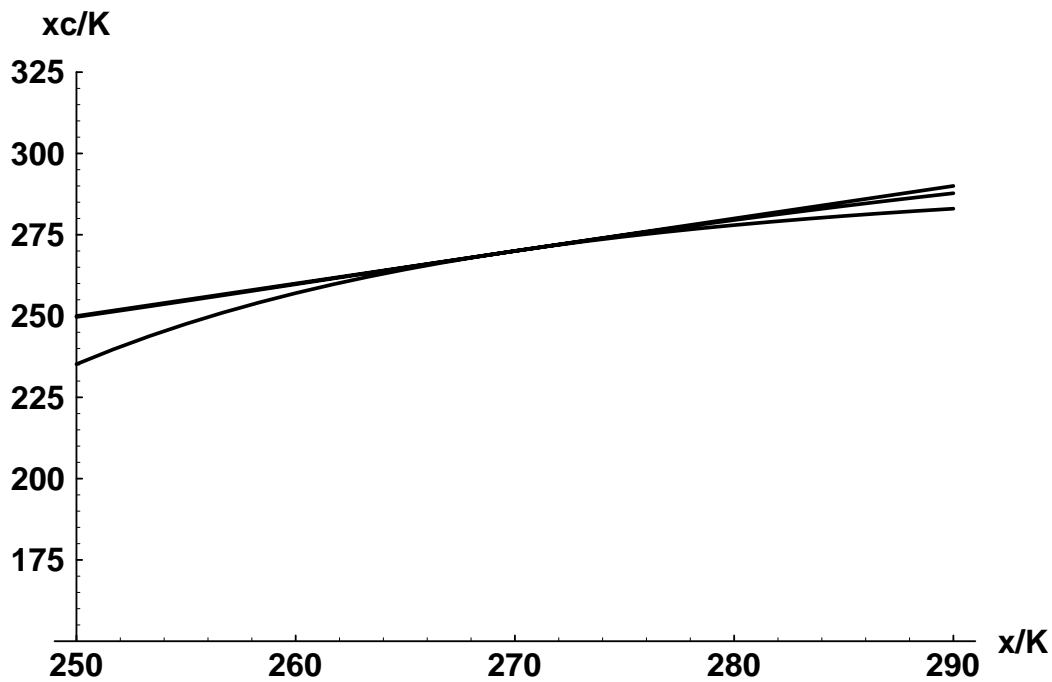

There are more elaborate networks which can be used to linearize thermistor response. These will not be covered.



Symbol:

Temperature range: about -220°C to 750°C (Platinum).

Construction:

Transducer is a metal, usually platinum.

Metal is wound into a long coil ...

... or printed on a ceramic substrate in a serpentine pattern.

Inventor: C. H. Meyers in 1932.

Resistance change of metals discovered in 1821 by Sir Humphrey Davy.

Use of platinum for temperature measurement ...

... suggested by Sir William Siemens in 1871.

Principle of Operation

In normal operation a current is flowing through RTD.

As the temperature increases, ...

... electrons collide more frequently with metal atoms ...

... increasing resistance.

Desirable Characteristics

- Accurate. (An RTD used to define part of ITS-90.)
- Stable.
- Wide temperature range.
- Reasonably linear.
- Available in standard types.

Undesirable Characteristics

- Low sensitivity.
(Small resistance change with temperature.)
- Expensive.

RTD Model Function

For a properly constructed transducer ...

... the following function is exact for ITS-90:

$$H_{t0}(x) = R_0 \left(C_0 + \sum_{i=1}^9 C_i \left(\frac{x/\text{K} - 754.15}{481} \right)^i \right),$$

for $x \in (0^\circ\text{C}, 961.78^\circ\text{C})$, where $R_0 = H_{t0}(273.16\text{ K})$ and the C_i are constants defined in the ITS-90 standard.

This function is accurate (but not exact) and easier to use:

$$H_{t1}(x) = R_0(1 + \alpha_1 x + \alpha_2 x^2).$$

Platinum RTDs are usually made so that $R_0 = 100\ \Omega$.

For platinum, $\alpha_1 = 0.00398/^\circ\text{C}$ and $\alpha_2 = -5.84 \times 10^{-7}/^\circ\text{C}^2$.

Three-Wire Configuration

Problem with RTDs: lead resistance is significant.

Lead resistance may change with temperature.

Not necessarily the temperature being measured!.

Leads can be shortened or lengthened, changing resistance.

Solution: three-wire RTD.

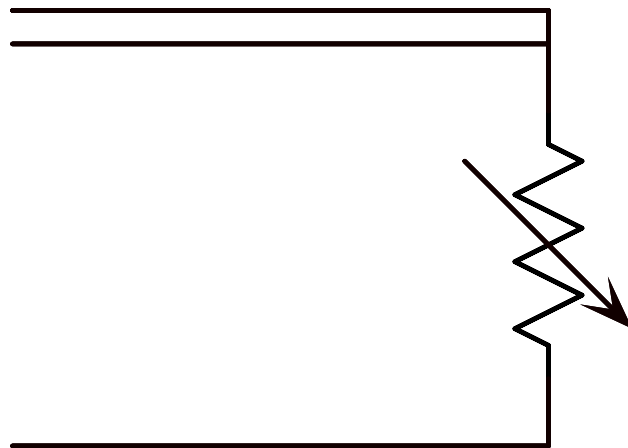

Three-Wire RTD Use

When used in a Wheatstone bridge, ...

... unwanted resistances have little effect on output.

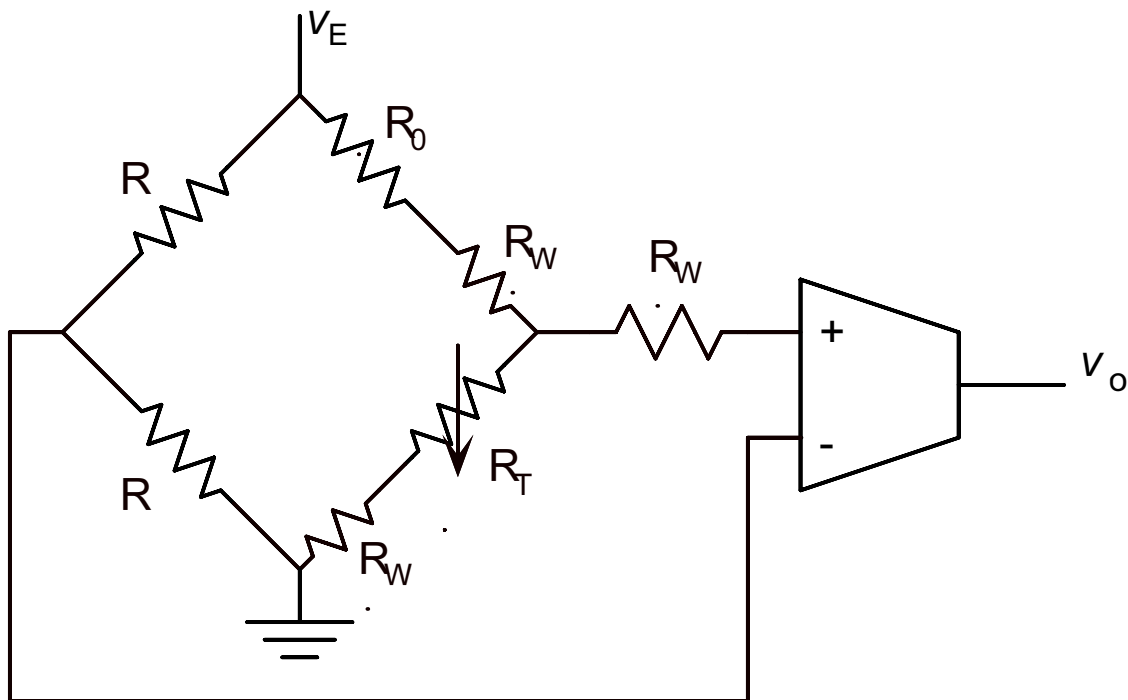

R_w is resistance of wire. Output, v_o , should not be a function of this.

Re-write RTD function as $H_t(x) = R_0 + R_0 H'_t(x)$,

where $H'_t(x) = \alpha_1 x + \alpha_2 x^2$.

$$v_o = Av_E \left(\frac{\frac{1}{2} R_0 H'_t(x)}{R_0 H'_t(x) + 2R_w + 2R_0} \right) \approx \frac{Av_E}{4} H'_t(x).$$



Temperature range: about $[-270^{\circ}\text{C}, 1820^{\circ}\text{C}]$.

Construction:

- Two metals joined (*e.g.*, welded together).
- Transducer is junction (weld).
- Leads, connecting to metals, specially constructed.

Principle of Operation

When dissimilar metals joined, an EMF develops across the junction. (As in semiconductor PN junctions.)

Strength of EMF is a function of metals used and junction temperature.

Temperature is determined by measuring voltage.

Measuring this voltage is not as easy as one might think...

History

Effect of EMF discovered in 1821 by Thomas Seebeck.

Desirable Characteristics

Very wide temperature range: freezer to furnace.

Rugged.

Accurate.

Highly standardized.

- Connectors and color of cables are all part of the standard.
- Tables of thermocouple voltages published by ...
... National Institute of Standards and Technology (NIST).

No self-heating.

(Conditioning circuit does not warm transducer.)

Undesirable Characteristics

Difficult to measure voltage.

Non-linear.

Transducer Model Functions

Best: $H_{t1}(x)$, thermocouple tables published by NIST.

Over a narrow temperature range:

$$H_{t3}(x) = v_M(1 + \alpha(x - T_M)) \dots$$

... where α is a constant called ...

... the *Seebeck Coefficient*.

In most cases a lookup table, $H_{t1}(x)$, would be used.

Consider two joined metals:

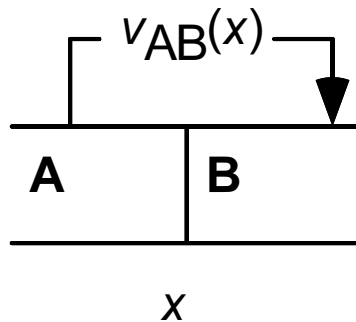

Potential developed, $v_{AB}(x)$, a function of metals and temperature.

Inserted Metals

Consider two junctions in series, junction AX at x_1 and junction XB at x_2 :

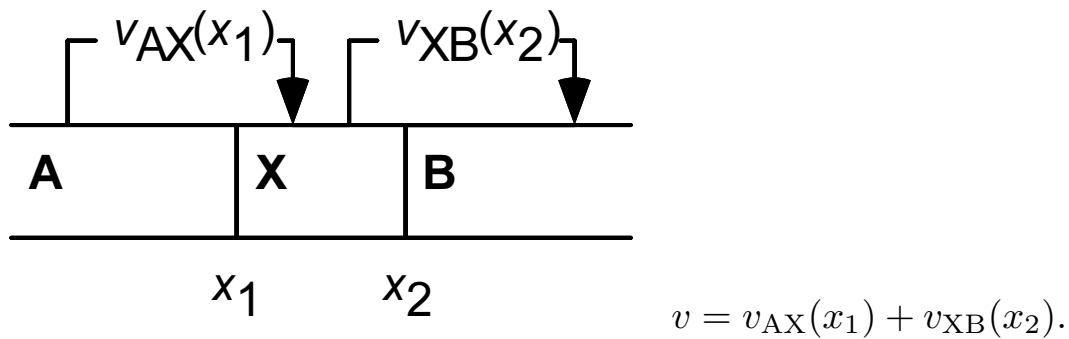

If $x_1 = x_2 = x$ then $v = v_{AX}(x) + v_{XB}(x) = v_{AB}(x)$.

This is referred to as the *law of inserted metals*.

Used to show, among other things, ...

... that thermocouple junctions can be welded.

Measurement of Seebeck Voltage

Consider the following setup:

Note that both voltmeter connections are at same temperature.

Schematically,

$$\begin{aligned}v_M &= v_{CA}(T_r) + v_{AB}(x) + v_{BC}(T_r) \\ &= v_{AB}(x) + v_{BA}(T_r) \\ &= v_{AB}(x) - v_{AB}(T_r)\end{aligned}$$

To determine x must know T_r .

Note that v_M is not a function of metal C, making life easier for us.

Isothermal Block

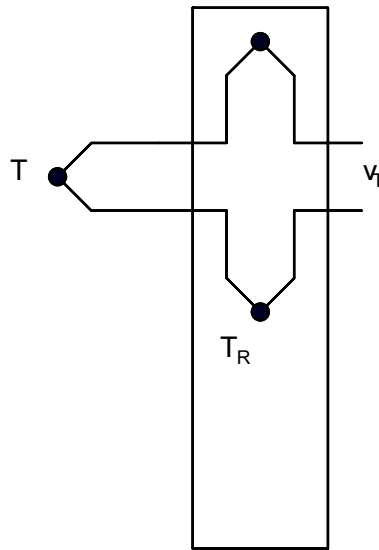

Block upon which connections to thermocouple leads are made.

All parts of block are kept at the same temperature.

Called the *reference temperature*, and denoted T_r .

Either ...

... block is maintained at a known temperature.

(*E.g.*, placed in an ice bucket.)...

... or block also includes a temperature sensor.

Either way, T_r is treated as part of the conditioning circuit.

Using isothermal block, $v_{AB}(T)$ can be determined.

Standard Thermocouple Tables

Published by NIST.

Some standard thermocouples:

- *Type J*: Iron vs. Copper-Nickel.
Temperature range: $[-210\text{ }^{\circ}\text{C}, 760\text{ }^{\circ}\text{C}]$.
- *Type K*: Nickel-Chromium vs. Nickel-Aluminum.
Temperature range: $[-270\text{ }^{\circ}\text{C}, 1372\text{ }^{\circ}\text{C}]$.
- *Type R*: Platinum- 13% Rhodium vs. Platinum.
Temperature range: $[0\text{ }^{\circ}\text{C}, 1767\text{ }^{\circ}\text{C}]$.

Thermocouple Table Entries

Standard thermocouple tables give :

$$v = H_{XY}(x) = v_{AB}(x) - v_{AB}(0\text{ }^{\circ}\text{C})$$

and

$$x = H_{XY}^{-1}(v), \text{ where } XY \text{ is the type of thermocouple.}$$

Temperatures in tables used for class are on the IPTS-68 scale.

Example:

A voltage of 6.86 mV is measured at an isothermal block connected to a Type-R thermocouple. The block is at 0 °C. What is the thermocouple temperature?

According to the table, $H_{\text{TypeR}}(710\text{ }^{\circ}\text{C}) = 6.860\text{ mV}$.

So, temperature is 710 °C.

When Isothermal Block is not at 0°C :

Recall, $H_{XY}(x) = v_{XY}(x) - v_{XY}(0^\circ\text{C})$.

Consider a measurement where $T_r \neq 0^\circ\text{C}$.

Then we need: $v_{XY}(x) - v_{XY}(T_r)$.

This is equal to $H_{XY}(x) - H_{XY}(T_r)$.

Example:

A voltage of 6.860 mV is measured at an isothermal block connected to a Type-R thermocouple. The block is at 23°C . What is the thermocouple temperature?

By the Type-R thermocouple table ...

... $H_{\text{TypeR}}(710^\circ\text{C}) = 6.860\text{ mV}$ and $H_{\text{TypeR}}(23^\circ\text{C}) = 0.129\text{ mV}$.

Measured voltage is $v_{\text{TypeR}}(x) - v_{\text{TypeR}}(T_r) = 6.860\text{ mV}$.

Subtract $v_{\text{TypeR}}(0^\circ\text{C})$ from both sides and solve for $v_{\text{TypeR}}(x) - v_{\text{TypeR}}(0^\circ\text{C})$.

Substituting values, $v_{\text{TypeR}}(x) - v_{\text{TypeR}}(0^\circ\text{C}) = 6.989\text{ mV}$.

Based on table, $x = 721^\circ\text{C}$.

Compensate for temperature of isothermal block.

Other Names:

Electronic ice point.

Hardware compensation.

Details

Consider an isothermal block ...

... with a built-in temperature transducer.

A circuit which converts the voltage at the thermocouple leads ...

... from $v_{XY}(x) - v_{XY}(T_r)$, ...

... to $v_{XY}(x) - v_{XY}(0^\circ\text{C})$...

... is called an *electronic ice bath circuit*.

These can be built from passive components or active devices.

An example of an ice-bath circuit ...

... will follow integrated temperature sensors.

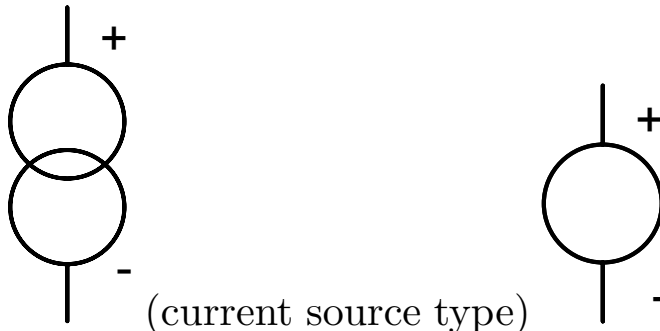

Symbols: (current source type) (volt. source type).

Temperature range: about -100°C to 200°C . (Relatively narrow.)

Construction:

Transducer (usually diode) mounted ...
... in same package as conditioning circuit.

Principle of Operation

Temperature is sensed by some transducer.

Conditioning circuit converts temperature to ...
... a voltage or current ...
... (depending on type).

Voltage or current output is in user (engineer)-friendly form.

Desirable Characteristic

- Linear, human-oriented output.
(*E.g.*, current in microamps is temperature in Kelvins.)

Undesirable Characteristics

- Narrow temperature range.
- Slow response to temperature changes.
- Fragile.

Typical Functions

Voltage type: $H_{t1}(x) = x \frac{10 \text{ mV}}{\text{K}}$.

Current type: $H_{t1}(x) = x \frac{\mu\text{A}}{\text{K}}$.

Use

Current type must have at least several volts bias.

Current type best ...

... when resistance of leads may be significant, ...

... as when long leads are used.

Design a circuit to convert a temperature, $x \in [100^\circ\text{C}, 1760^\circ\text{C}]$, to a floating-point number stored in variable `tee`, where $\text{tee} = H(x) = x \frac{1}{^\circ\text{C}}$. Use the following:

- *A Type-R thermocouple.*
- *A 2100-entry Type-R thermocouple table ...
... stored as an array in the computer's memory.*
- *An isothermal block ...
... with an integrated temperature sensor ...
... having response $H_{\text{its}}(x) = x \frac{\mu\text{A}}{\text{K}}$.*

*The isothermal block will be exposed ...
... to temperatures in the range $[5^\circ\text{C}, 50^\circ\text{C}]$.*

Solution Plan:

- Design circuit.
- Choose component values.
- Write code to compute answer.

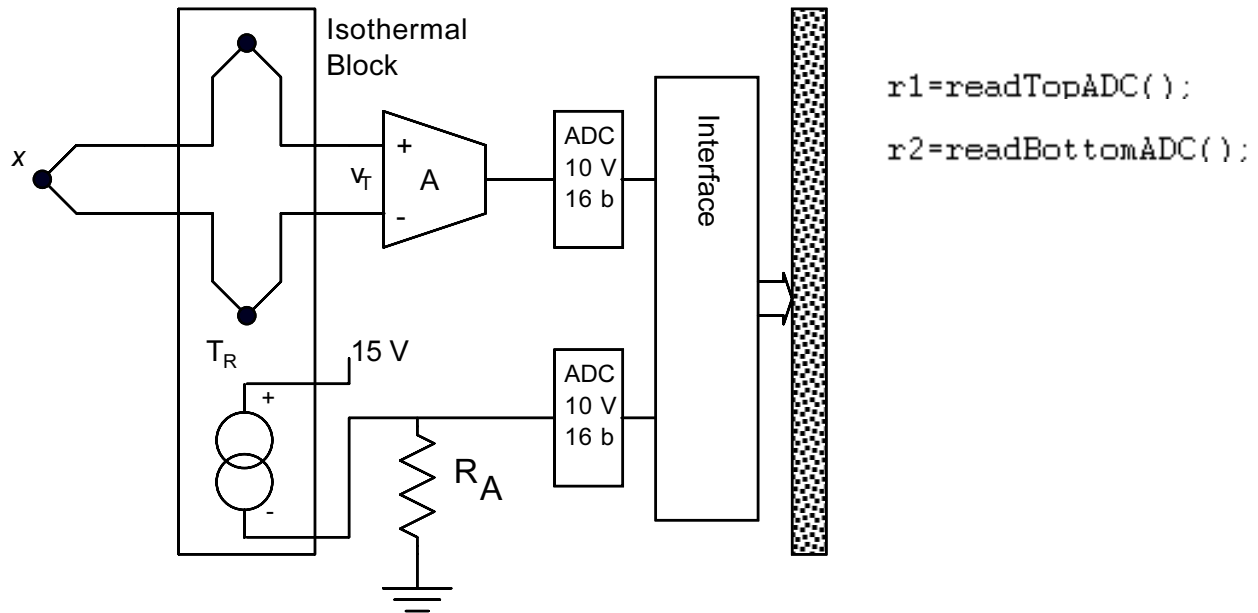

Circuit

Call response of thermocouple $H_{\text{TypeR}}(x)$.

Use two ADCs, ...

... one for thermocouple ...

... and one for integrated temperature sensor.

ADC function: $H_{\text{ADC}(v_{\text{ADC}},b)}(x) = H_{\text{ADC}(10\text{ V},16)}(x)$.

Use instrumentation amplifier with gain A ...

... to condition thermocouple output for ADC input.

Call response of this circuit H_{c1} .

Use resistor, R_A , and voltage source ...

... to condition integrated temperature sensor for ADC input.

Call response of this circuit H_{c2} .

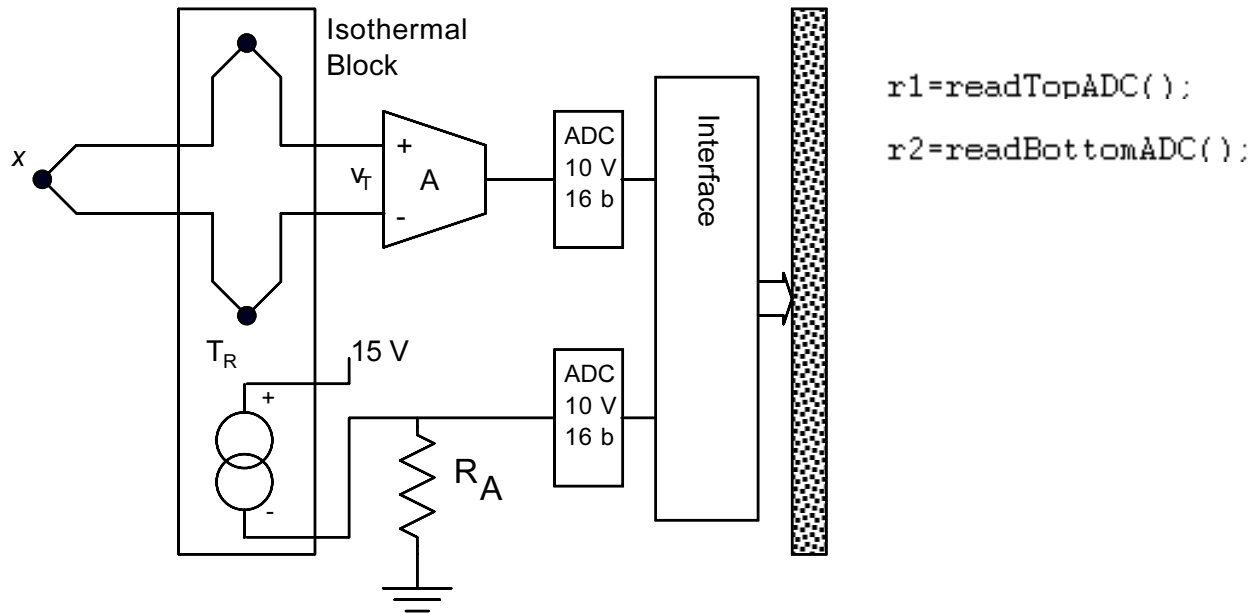

Instrumentation Amplifier Gain

ADC input cannot exceed 10 V.

Note: maximum occurs when x is at its maximum and T_r is at its minimum.

Value for $H_{\text{TypeR}}(x)$ is found in Type-R thermocouple table.

$$0 \text{ V} \leq H_{c1}(H_{\text{TypeR}}(x) - H_{\text{TypeR}}(T_r)) \leq v_{\text{ADC}}$$

$$0 \text{ V} \leq A(H_{\text{TypeR}}(x) - H_{\text{TypeR}}(T_r)) \leq 10 \text{ V}$$

Minimum voltage: $H_{\text{TypeR}}(100^\circ\text{C}) - H_{\text{TypeR}}(50^\circ\text{C}) = 0.351 \text{ mV}$.

Maximum voltage: $H_{\text{TypeR}}(1760^\circ\text{C}) - H_{\text{TypeR}}(5^\circ\text{C}) = 20.979 \text{ mV}$.

Therefore, $A < 477$ must be satisfied. Choose $A = 450$.

Makes use of more than 92% of ADC's dynamic range. (Good.)

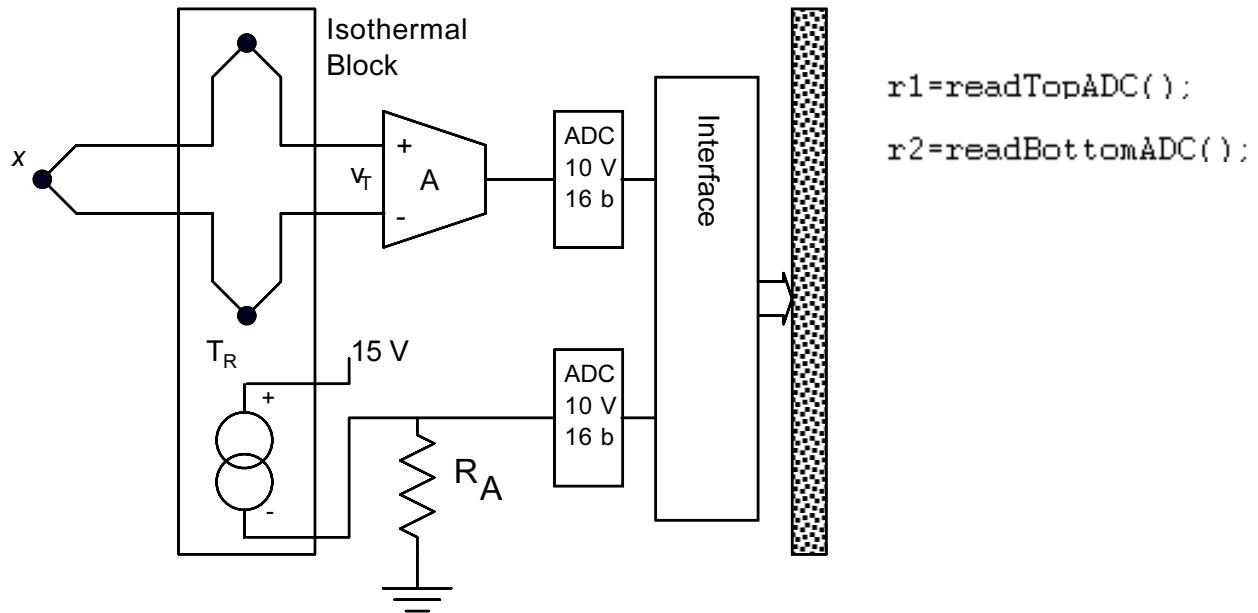

Resistance Of R_A

Constraint: $0 \text{ V} \leq H_{c2}(H_{its}(T_r)) \leq v_{\text{ADC}}$

Current-to-voltage circuit: $H_{c2}(y) = yR_A$.

$$0 \text{ V} \leq \mu\text{A} \frac{T_r}{\text{K}} R_A \leq 10 \text{ V}.$$

$$R_A < \frac{10 \text{ V K}}{323.15 \text{ K } \mu\text{A}} = 30.945 \text{ k}\Omega$$

Choose: $R_A = 20 \text{ k}\Omega$.

Makes use of $< 10\%$ of ADC's dynamic range. (Wasteful.)

Possible test or homework question: ...

... "How can the circuit be modified ...

... to make greater use of the ADC's dynamic range?"

Interface Routine

Call the value read from the thermocouple input **r1** ...
 ... and call value from integrated temperature sensor **r2**.

$$r1 = H_{\text{ADC}(10\text{ V},16)}(H_{c1}(H_{\text{TypeR}}(x) - H_{\text{TypeR}}(T_r)))$$

Need to satisfy:

$$H_f(H_{\text{ADC}(10\text{ V},16)}(H_{c1}(H_{\text{TypeR}}(x) - H_{\text{TypeR}}(T_r)))) = H(x) = \frac{x}{^\circ\text{C}}$$

Let $z = H_{\text{ADC}(10\text{ V},16)}(H_{c1}(H_{\text{TypeR}}(x) - H_{\text{TypeR}}(T_r)))$ and solve for x .

$$x = H_{\text{TypeR}}^{-1} \left(z \frac{v_{\text{ADC}}}{2^b - 1} \frac{1}{A} + H_{\text{TypeR}}(T_r) \right).$$

$$H_f(z) = H(x) = \frac{x}{\text{K}} - 273.15$$

Next find T_r .

$$r2 = H_{\text{ADC}}(H_{c2}(H_{\text{its}}(T_r))). \text{ Solving, } T_r = \frac{r2 \text{ K} v_{\text{ADC}}}{(2^b - 1) \mu\text{A} R_A}.$$

Let function **hTyR(T)** return the thermocouple voltage ...
 ... at temperature **T** with reference temperature 0°C .

Let function **hTyRi(v)** return the thermocouple temperature ...
 ... when the measured voltage is **v** with reference temperature 0°C .

Then:

$$\text{double } t_ref = r2 * 7.6293\text{E-}9; /* = r2 \frac{1}{R_A} \frac{v_{\text{ADC}}}{2^b - 1} */$$

$$\text{double } tee = \text{hTyRi}(r1 * 3.390\text{E-}7 + \text{hTyR}(t_ref)) - 273.15;$$

Lookup Function

Store Type-R thermocouple table (from NIST) in a 2100-entry array.

Function $hTyR(T)$ returns voltage if there is an entry for T .

Otherwise, it looks up two closest values in table.

A voltage is interpolated and returned.

Function $hTyRi(T)$ works in a similar fashion.