

Measures of Fluid Flow

- *Flow velocity.*
Speed of material flowing past a plane.
- *Volumetric flow.*
Volume of material passing a plane per unit time.
- *Mass flow.*
Mass of material passing a plane per unit time.

When fluid incompressible . . .

. . . flow velocity, volumetric, and mass flow are proportional.

Types of Flowing Fluids to be Measured

- Liquid in closed conduit. (*E.g.*, water in a pipe.)
- Liquid in an open conduit. (*E.g.*, water in a canal.)
- Gas in an closed conduit.
- Slurry (solids suspended in liquids) in a closed conduit.

Different transducers may be required for each situation.

Some Major Types of Sensors

- *Rotation.*

Fluid forces an object placed in flow to rotate. Speed of rotation is measured.

- *Obstruction.*

Fluid flow is partially obstructed. Pressure is measured on both sides of obstruction, flow rate deduced.

- *Heat dissipation.*

A heating element is placed in the flow. Flow rate deduced by amount of heat removed.

- *Head.*

Measure fluid level flowing into a drop.

Force of flow causes some object to rotate. Two types will be discussed, turbine and paddle wheel.

Turbine Type

Used to measure volumetric flow in a closed conduit.

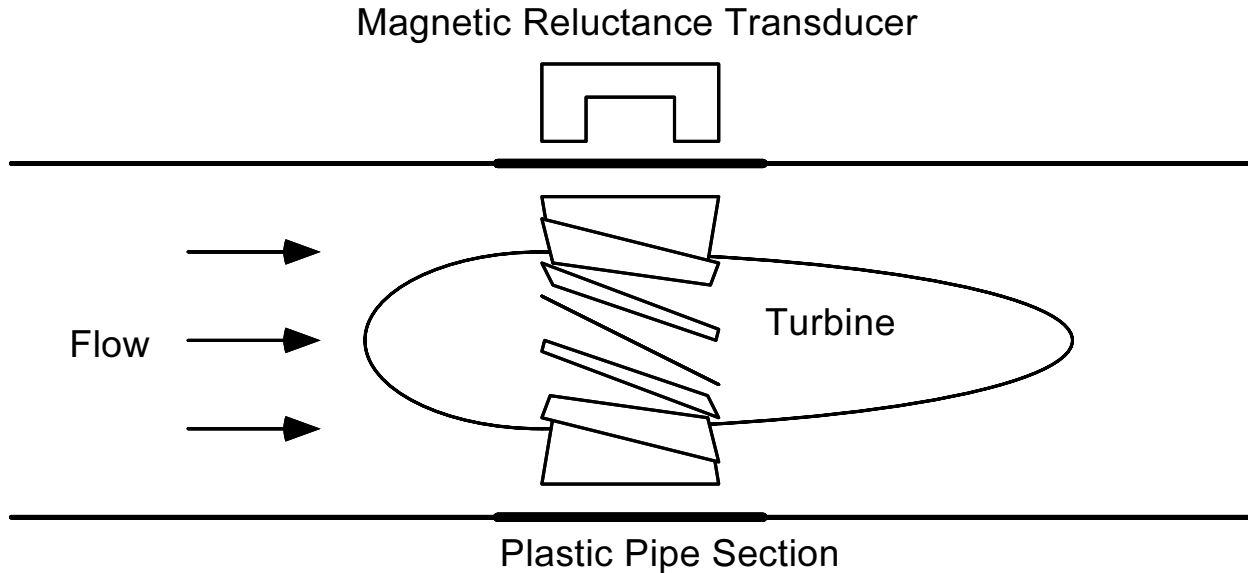

Typical Construction.

Turbine placed in flow in a plastic section of pipe.

Turbine blades made of metal.

Magnetic reluctance transducers placed outside pipe near blades.

Flow causes turbine to spin.

Rate of spin measured by magnetic reluctance sensor.

Model Function

This includes the turbine, the magnetic reluctance sensor, a conditioning circuit, and a frequency counter.

$H_{t1}(x) = kx$, where k is a constant called the k factor, having units of one over volume.

Paddle Wheel

Used to measure volumetric flow in an open conduit.

Consists of a wheel partially immersed in the flow.

Flow causes wheel to turn.

Same model function as turbine flow meter.

Design a system to convert process variable $x \in [0, 80 \frac{\text{ml}}{\text{s}}]$, flow in a pipe, into a floating-point number $H(x)$ to be written into variable `paddleFlow`, where $H(x) = x \frac{\text{s}}{\text{ml}}$. The value must have a precision of $\pm 0.1 \frac{\text{ml}}{\text{s}}$. Use an FP-2502 paddle-wheel flow sensor.

Solution Overview

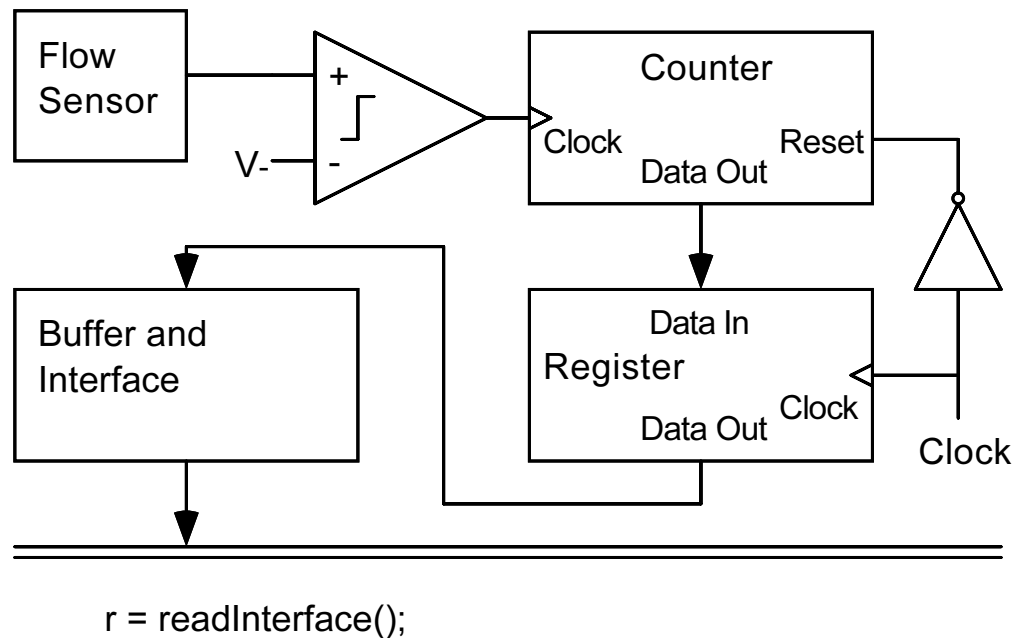

Flow sensor generates a voltage pulse train.

Digital comparator converts to logic level.

Counter counts pulses.

At regular intervals count transferred to register, and counter reset.

At irregular intervals interface routine reads register and completes conditioning.

The FP-2502 Flow Sensor

Output pulse minimum 2 V.

For each ml flow there are 8.5 pulses.

Measurable range, $\left[50 \frac{\text{ml}}{\text{min}}, 6000 \frac{\text{ml}}{\text{min}} \right]$.

Cost, \$530.

Design Decisions

Threshold for digital comparator.

Number of bits in counter and register.

Amount of time between *samplings* of counter.

Interface routine.

Digital Comparator Threshold

Set negative input to slightly less than 2 V.

Counter Contents

Let $H_{\text{ctr}}(x, t)$ give the counter value t time after being reset, where x is the flow rate.

Then, $H_{\text{ctr}}(x, t) = x k t$, where $k = \frac{8.5}{\text{ml}}$. (This assumes that x is constant while the counter is counting.)

Let t_c denote the amount of time that the counter counts before its contents are transferred to the register.

Let $H_r(x)$ give the value clocked into the register.

Then $r = H_r(x) = H_{\text{ctr}}(x, t_c) = x \frac{8.5}{\text{ml}} t_c$.

This value will be read by the interface routine.

Solving for x yields $x = r \frac{\text{ml}}{8.5} \frac{1}{t_c}$.

To obtain H_f :

$$\begin{aligned} H_f(H_r(x)) &= H(x) \\ H_f(r) &= H\left(r \frac{\text{ml}}{8.5} \frac{1}{t_c}\right) \\ &= \frac{\text{s}}{\text{ml}} r \frac{\text{ml}}{8.5} \frac{1}{t_c} \\ &= r \frac{1}{8.5 t_c} \text{ s} \end{aligned}$$

To complete the solution choose t_c and the number of bits in the counter and register.

Precision goal is $\pm 0.1 \frac{\text{ml}}{\text{s}}$.

Smallest change in r is ± 1 .

Therefore constraint $H_f(r) - H_f(r - 1) \leq 0.1$ must hold.

Applying H_f , $\frac{1}{8.5} \frac{1}{t_c} s(r - (r - 1)) \leq 0.1$.

As a safety margin, solve $\frac{1}{8.5} \frac{1}{t_c} s = 0.025$.

$t_c = 4.706 \text{ s}$.

Then, $H_r(80 \frac{\text{ml}}{\text{s}}) = 3200$. Therefore a 12-bit counter is needed.

Interface routine code:

```
r = readInterface();  
paddleFlow = r * 0.025;
```

Used to measure volumetric flow in closed conduits.

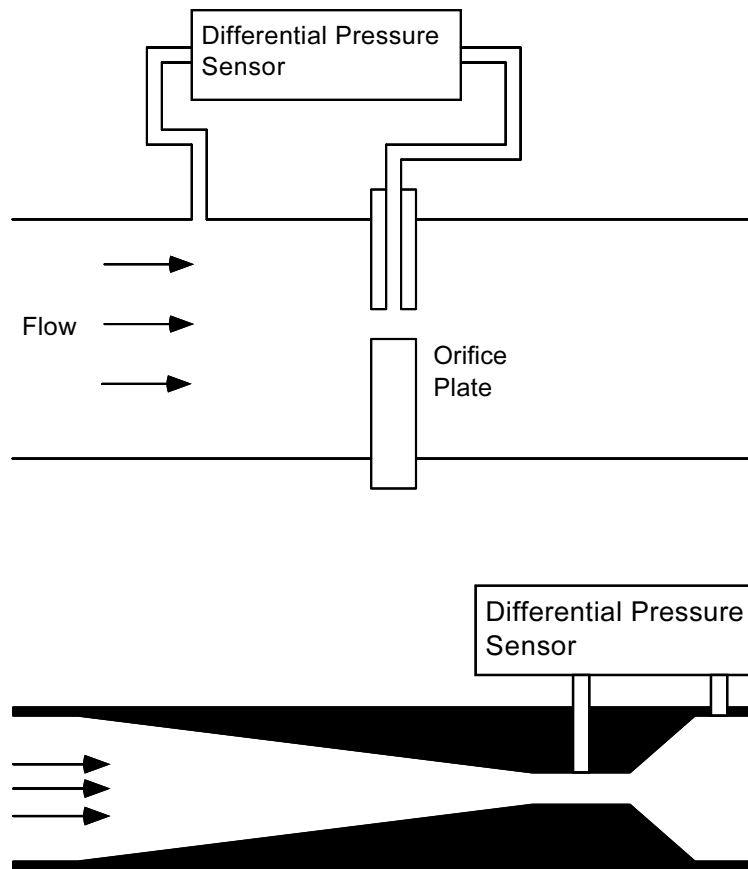

Typical Construction

An obstruction placed in pipe.

Obstruction might be:

- a plate with hole in center (called an *orifice plate*) or
- a carefully shaped venturi tube.

Obstruction causes a pressure difference.

Pressure difference measured with a differential pressure sensor.

Flow rate deduced from differential pressure.

Model Function

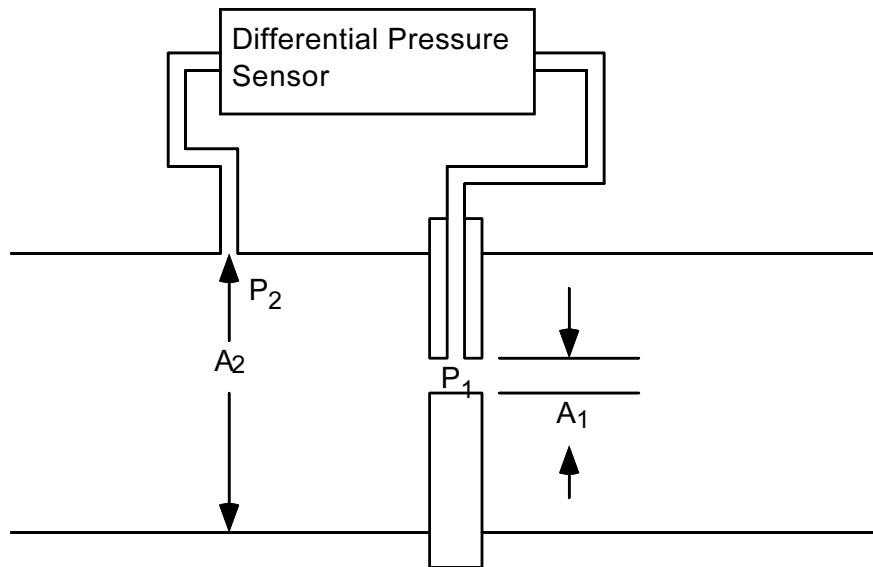

Consider an obstruction flow meter in which:

the pipe is in a horizontal position,

the fluid is incompressible and of density δ ,

the area at point 1 is A_1 , the area at point 2 is A_2 ,

and the pressure at point 1 is P_1 and the pressure at point 2 is P_2 .

The model function for such a transducer is

$$H_{t1}(x) = x^2 \frac{\delta(1 - (A_1/A_2)^2)}{2C_d^2 A_1^2} = P_2 - P_1,$$

where C_d is a constant called the *discharge coefficient*.

In an ideal transducer, $C_d = 1$.

For a typical venturi tube, $C_d = .97$ and for a typical orifice plate, $C_d = .6$.

Example Problem

Convert the process variable $x \in [0\frac{1}{\text{min}}, 1000\frac{1}{\text{min}}]$, volumetric flow of water in a 50 mm diameter pipe, to a floating point number $H(x)$ stored in variable `vflow` where $H(x) = x\frac{\text{min}}{1}$. Use an Omega brand PX 820-070DV differential pressure sensor and an ADC with response $H_{\text{ADC}}(10\text{ V}, 10)$.

Solution Diagram:

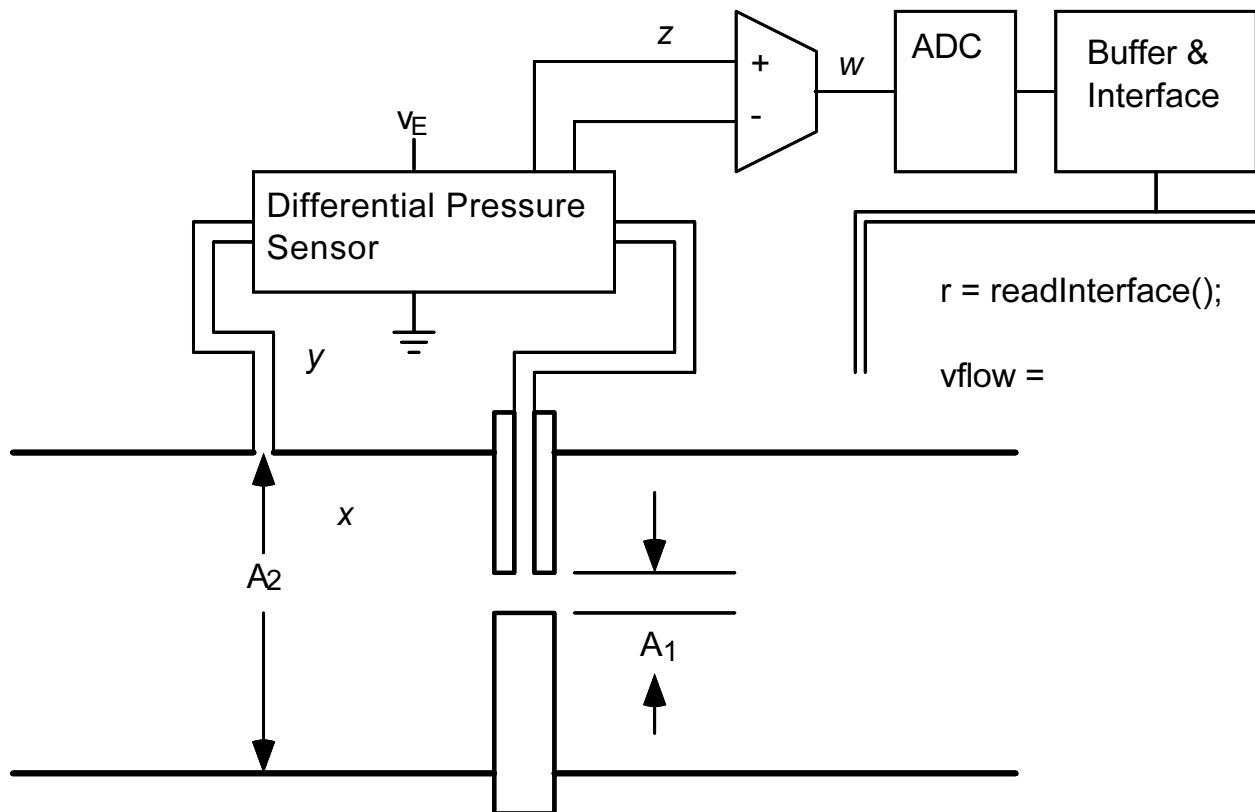

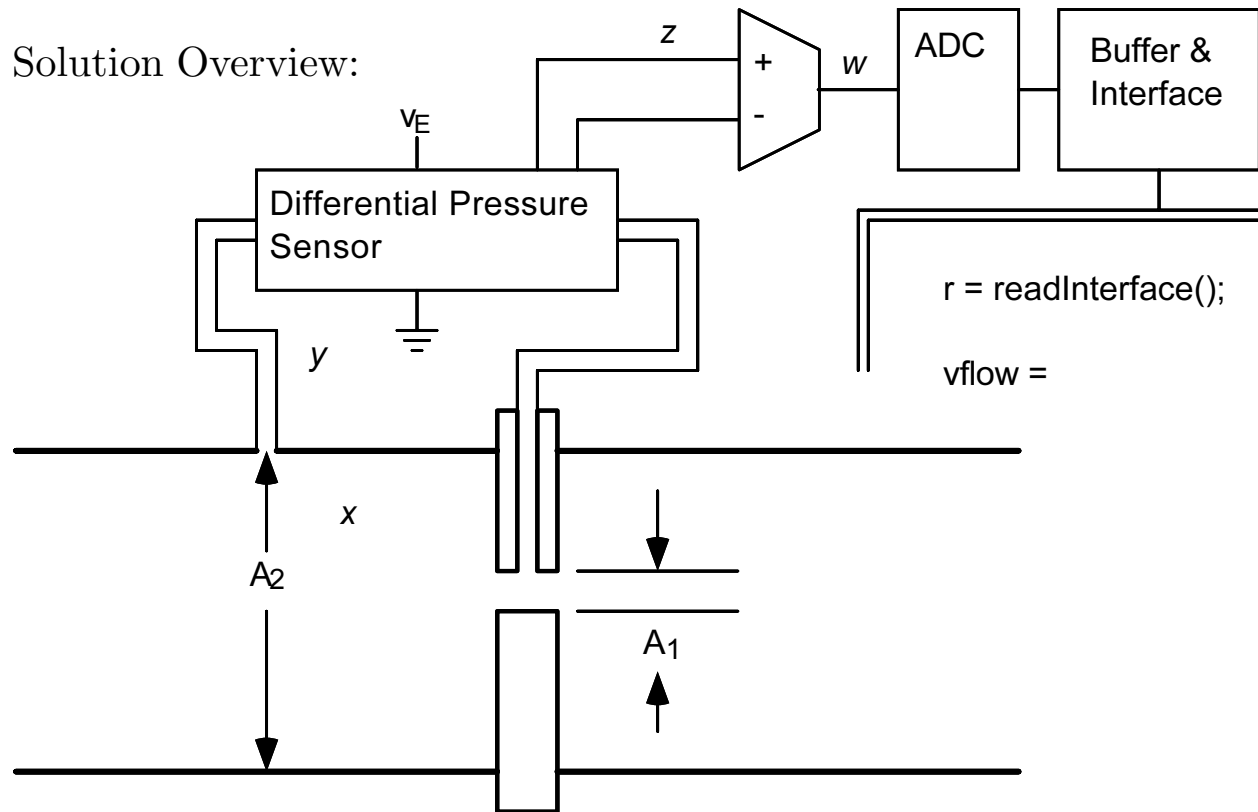

- Use an orifice plate flow transducer. Call area of orifice A_1 .

Call response and output of flow transducer

$$y = H_{t1}(x) = x^2 \frac{\delta(1 - (A_1/A_2)^2)}{2C_d^2 A_1^2}.$$

- Use the differential pressure transducer to convert pressure difference to voltage.

Response of Omega brand PX 820-070DV differential pressure sensor is

$$z = H_p(y) = \frac{y}{p_{\max}} 100 \text{ mV}$$

for a 5 V excitation and for $y \in [0, p_{\max}]$ where $p_{\max} = 5 \text{ bar}$.

Solution Overview:

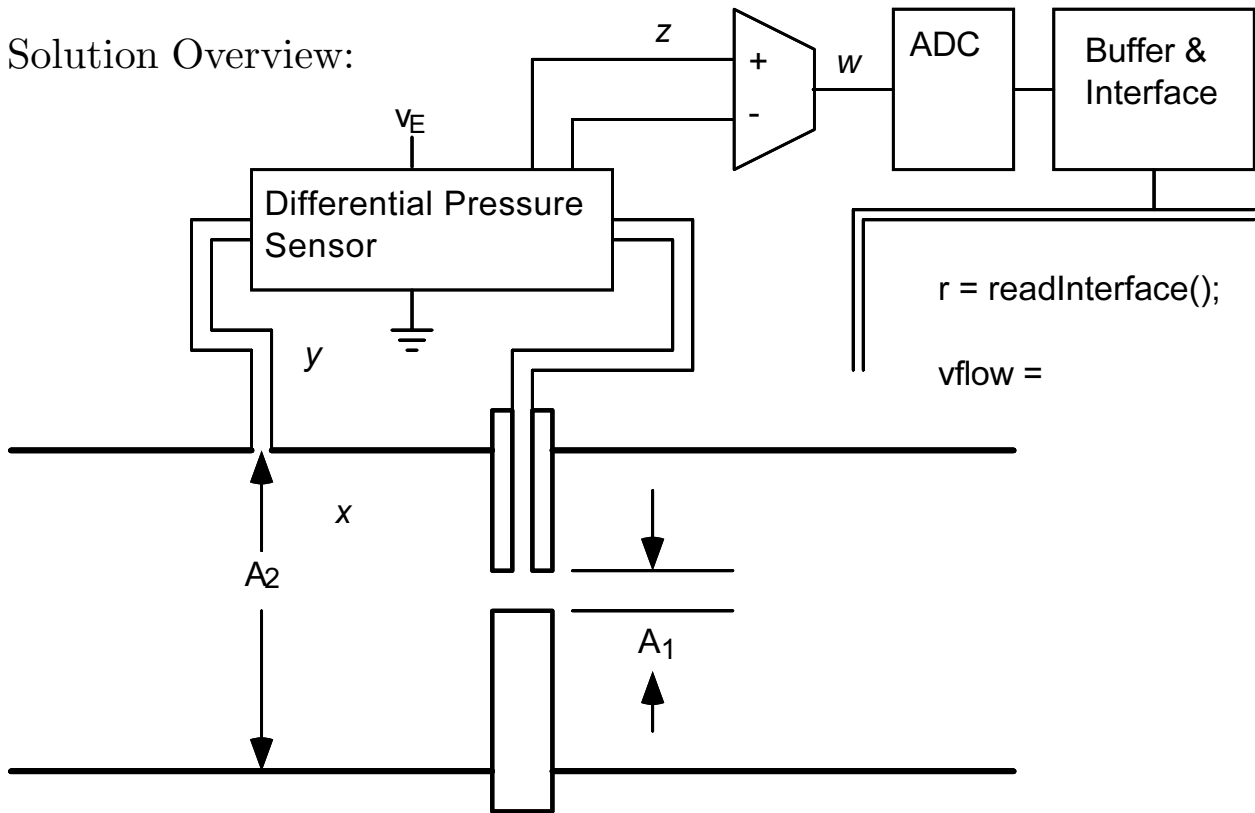

- Use an instrumentation amplifier to amplify the voltage for the ADC. Response is $w = H_c(z) = gz$. (Symbol g is being used for gain instead of A .)
- Use the ADC and an interface circuit to prepare the data for the computer.

Response is $r = H_{\text{ADC}(10\text{ V},10)}(w) = \frac{w}{10\text{ V}}1023.$

- Write an interface routine, H_f , to produce the desired output:

$$H_f(H_{\text{ADC}(10\text{ V},10)}(H_c(H_p(H_{t1}(x)))))) = H(x) = x \frac{\min}{1}.$$

Constraints and Solution Plan:

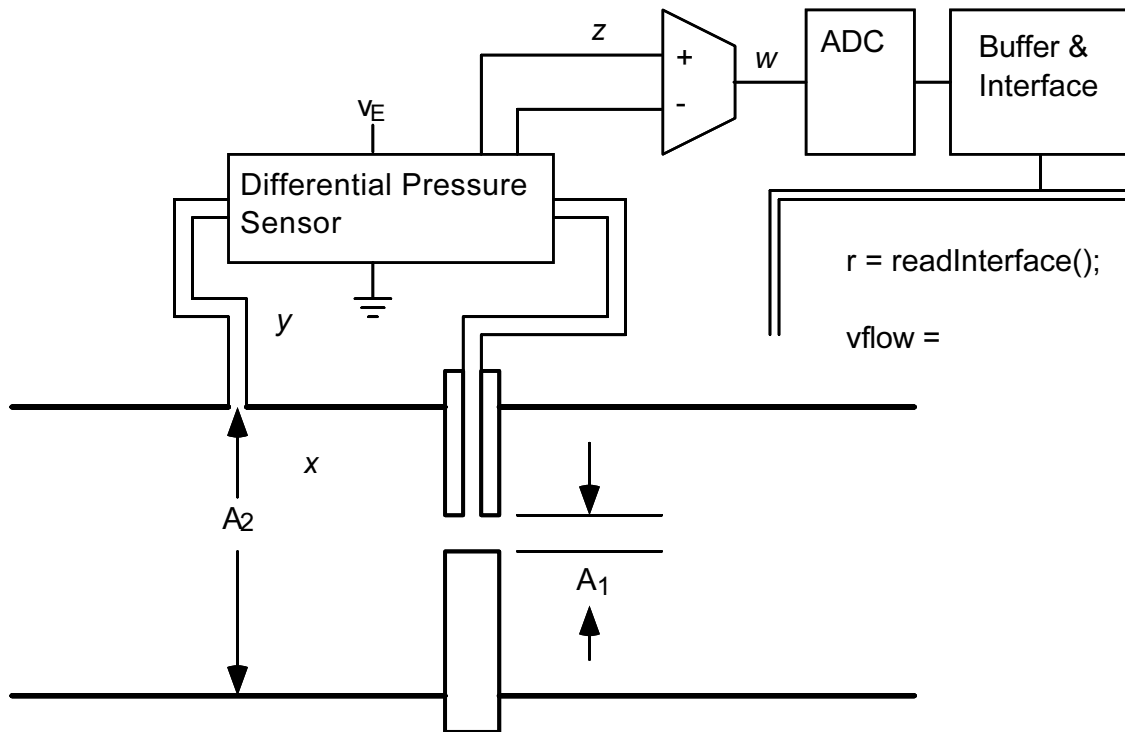

- Choose orifice diameter so that differential pressure is in range $[0, p_{\max}]$:

$$0 \leq H_{t1}(x) \leq p_{\max} = 5 \text{ bar} \quad \text{for } x \in \left[0 \frac{1}{\text{min}}, 1000 \frac{1}{\text{min}}\right]$$

- Choose amplifier gain, g , so that ADC input is in range $[0, 10 \text{ V}]$:

$$0 \leq H_c(H_p(H_{t1}(x))) \leq 10 \text{ V} \quad \text{for } x \in \left[0 \frac{1}{\text{min}}, 1000 \frac{1}{\text{min}}\right]$$

- Write interface routine to get desired output.

Orifice Plate Diameter

To make full use of the pressure sensor's dynamic range ...
... choose A_1 so that:

$$0 \leq H_{t1}(x) \leq p_{\max} = 5 \text{ bar}$$

$$0 \leq x^2 \frac{\delta(1 - (A_1/A_2)^2)}{2C_d^2 A_1^2} \leq p_{\max} = 5 \text{ bar},$$

where $\delta = 1 \frac{\text{g}}{\text{cm}^3}$, $A_2 = \pi(25 \text{ mm})^2$ and $C_d = .6$.

Solve $H_{t1}(x_{\max}) = p_{\max}$ for A_1 :

$$A_1 = \left(\frac{1}{A_2^2} - \frac{p_{\max}}{\frac{\delta}{2} \left(\frac{x_{\max}}{C_d} \right)^2} \right)^{-\frac{1}{2}} = 0.0008018 \text{ m}^2$$

Or, orifice diameter is 31.95 mm.

Amplifier Gain

To avoid confusion with A_1 and $A_2 \dots$
... let g denote amplifier gain.

Choose amplifier gain so that:

$$0 \leq H_c(H_p(H_{t1}(x))) \leq 10 \text{ V}$$

Since each function is monotonic and has a positive slope:

$$H_c(H_p(H_{t1}(x_{\max}))) = 10 \text{ V}$$

Substituting p_{\max} for $H_{t1}(x_{\max})$:

$$H_c(H_p(p_{\max})) = 10 \text{ V}$$

Applying functions: $g \frac{p_{\max}}{p_{\max}} 100 \text{ mV} = 10 \text{ V}$, so

$$g = 100.$$

Interface Routine

Output of ADC:

$$\begin{aligned}
 r &= H_{\text{ADC}(10\text{ V},10)}(H_c(H_p(H_{t1}(x)))) \\
 &= \frac{(2^{10} - 1)}{10\text{ V}} g \frac{100\text{ mV}}{5\text{ bar}} \frac{\delta}{2} \left(\frac{x}{C_d} \right)^2 \left(\frac{1}{A_1^2} - \frac{1}{A_2^2} \right)
 \end{aligned}$$

Solving for x yields

$$\begin{aligned}
 x &= \sqrt{\frac{10\text{ V}}{2^{10} - 1} \frac{1}{g} \frac{5\text{ bar}}{100\text{ mV}} \frac{2}{\delta} C_d^2 \left(\frac{1}{A_1^2} - \frac{1}{A_2^2} \right)^{-1} r} \\
 &= \sqrt{2.718 \times 10^{-7} \frac{\text{m}^6}{\text{s}^2} r}
 \end{aligned}$$

Need to find H_f such that:

$$H_f(H_{\text{ADC}(10\text{ V},10)}(H_c(H_p(H_{t1}(x)))))) = H(x) = x \frac{\text{min}}{1}$$

Substituting,

$$\begin{aligned}
 H_f(r) &= H \left(\sqrt{2.718 \times 10^{-7} \frac{\text{m}^6}{\text{s}^2} r} \right) = \sqrt{2.718 \times 10^{-7} \frac{\text{m}^6}{\text{s}^2} r} \frac{\text{min}}{1} \\
 &= 0.0005212 \frac{\text{m}^3}{\text{s}} \frac{\text{min}}{1} \sqrt{r} = 31.27 \sqrt{r}
 \end{aligned}$$

Interface routine:

```

r = readInterface();

vflow = 31.27 * sqrt( r );

```

Hot-Wire Anemometer

Used to measure mass flow in a closed or open conduit.

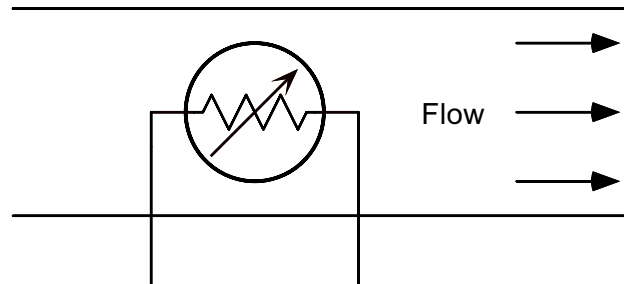

Construction:

A thermistor, RTD, or other self-heating temp. transducer placed in flow.

Fluid carries heat away from temperature transducer.

Transducer is maintained at a constant temperature by a feedback circuit.

Current is related to flow rate.

No model function or circuit will be given.

Two-Temperature Transducer Flow Meter

Used to measure mass flow in a closed or open conduit.

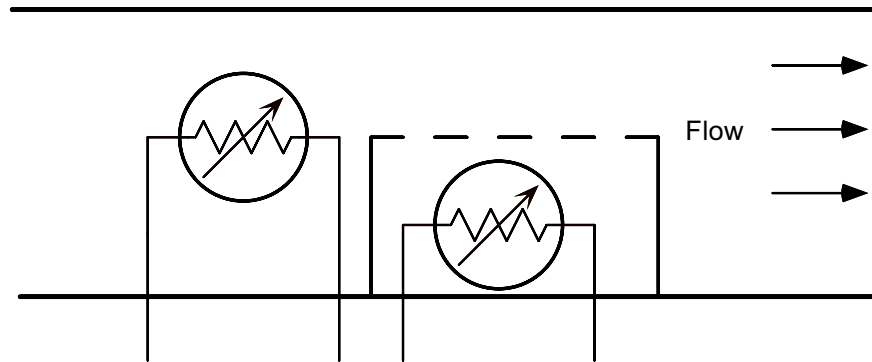

Construction:

Two temperature transducers placed in fluid.

One is exposed to flow.

The other is exposed to stationary fluid.

Transducers are connected in a bridge configuration.

No model function or circuit will be given.

Weir Flow Meter

Used to measure volumetric flow in open conduits.

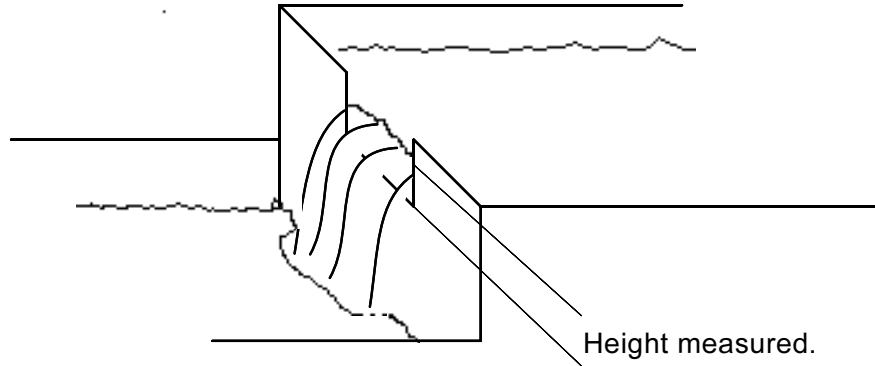

Construction:

Water flows in an open conduit (like an aqueduct), over a drop.

Shape of cut over which water falls is specially chosen.

Flow rate determined by height of water.

Model Function

For a rectangular cut, $H_{t1}(x) = k x^{2/3}$.

For a V-notch cut, $H_{t1}(x) = k x^{2/5}$.

Slurry Flow Measurement Methods

Flow contains a suspension of particles.

For example, coal mixed with water,
water with air bubbles, etc.

- *Sonar*. Measures flow velocity.

Sound injected nearly parallel to the direction of flow.

Microphones pick up reflected sound.

Speed determined by Doppler shift.

- *Cross correlation*. Measures flow velocity.

Some property is measured at two points in the flow, for example electrical resistance.

Let the two points be separated by a distance d .

Let $p_1(t)$ be the property measured at point 1 and time t .

Let $p_2(t)$ be the property measured at point 2 and time t .

The interface routine finds a Δt such that $p_1(t) \approx p_2(t + \Delta t)$ for some range $t \in [t_1, t_2]$.

The flow velocity is then $d/\Delta t$.